

2022 EDITION



# AIM MANUAL

60Hz SUBMERSIBLE SYSTEMS  
APPLICATION | INSTALLATION | MAINTENANCE



# COMMITMENT TO QUALITY

FRANKLIN ELECTRIC GLOBAL HEADQUARTERS &  
ENGINEERING DEVELOPMENT CENTER, FORT WAYNE, INDIANA

Franklin Electric is committed to providing high quality products and services to our customers. We are focused on a culture of continuous improvement to ensure we offer the best value to our customers.

## **ATTENTION!**

# **IMPORTANT INFORMATION FOR INSTALLERS OF THIS EQUIPMENT!**

THIS EQUIPMENT IS INTENDED FOR INSTALLATION BY TECHNICALLY QUALIFIED PERSONNEL. FAILURE TO INSTALL IT IN COMPLIANCE WITH NATIONAL AND LOCAL ELECTRICAL CODES, AND WITHIN FRANKLIN ELECTRIC RECOMMENDATIONS, MAY RESULT IN ELECTRICAL SHOCK OR FIRE HAZARD, UNSATISFACTORY PERFORMANCE, AND EQUIPMENT FAILURE. FRANKLIN INSTALLATION INFORMATION IS AVAILABLE FROM PUMP MANUFACTURERS AND DISTRIBUTORS, AND DIRECTLY FROM FRANKLIN ELECTRIC. CALL FRANKLIN TOLL FREE 800-348-2420 FOR INFORMATION.

## **WARNING**

SERIOUS OR FATAL ELECTRICAL SHOCK MAY RESULT FROM FAILURE TO CONNECT THE MOTOR, CONTROL ENCLOSURES, METAL PLUMBING, AND ALL OTHER METAL NEAR THE MOTOR OR CABLE, TO THE POWER SUPPLY GROUND TERMINAL USING WIRE NO SMALLER THAN MOTOR CABLE WIRES. TO REDUCE RISK OF ELECTRICAL SHOCK, DISCONNECT POWER BEFORE WORKING ON OR AROUND THE WATER SYSTEM. DO NOT USE MOTOR IN SWIMMING AREAS.

## **ATTENTION!**

# **INFORMATIONS IMPORTANTES POUR L'INSTALLATEUR DE CET EQUIPEMENT.**

CET EQUIPEMENT DOIT ETRE INTALLE PAR UN TECHNICIEN QUALIFIE. SI L'INSTALLATION N'EST PAS CONFORME AUX LOIS NATIONALES OU LOCALES AINSI QU'AUX RECOMMANDATIONS DE FRANKLIN ELECTRIC, UN CHOC ELECTRIQUE, LE FEU, UNE PERFORMANCE NON ACCEPTABLE, VOIRE MEME LE NON-FONCTIONNEMENT PEUVENT SURVENIR. UN GUIDE D'INSTALLATION DE FRANKLIN ELECTRIC EST DISPONIBLE CHEZ LES MANUFACTURIERS DE POMPES, LES DISTRIBUTEURS, OU DIRECTEMENT CHEZ FRANKLIN. POUR DE PLUS AMPLES RENSEIGNEMENTS, APPELEZ SANS FRAIS LE 800-348-2420.

## **AVERTISEMENT**

UN CHOC ELECTRIQUE SERIEUX OU MEME MORTEL EST POSSIBLE, SI L'ON NEGLIGE DE CONNECTER LE MOTEUR, LA PLOMBERIE METALLIQUE, BOITES DE CONTROLE ET TOUT METAL PROCHE DU MOTEUR A UN CABLE ALLANT VERS UNE ALIMENTATION D'ENERGIE AVEC BORNE DE MISE A LA TERRE UTILISANT AU MOINS LE MEME CALIBRE QUE LES FILS DU MOTEUR. POUR REDUIRE LE RISQUE DE CHOC ELECTRIQUE. COUPER LE COURANT AVANT DE TRAVAILLER PRES OU SUR LE SYSTEM D'EAU. NE PAS UTILISER CE MOTEUR DANS UNE ZONE DE BAIGNADE.

## **ATENCION!**

# **INFORMACION PARA EL INSTALADOR DE ESTE EQUIPO.**

PARA LA INSTALACION DE ESTE EQUIPO, SE REQUIERE DE PERSONAL TECNICO CALIFICADO. EL NO CUMPLIR CON LAS NORMAS ELECTRICAS NACIONALES Y LOCALES, ASI COMO CON LAS RECOMENDACIONES DE FRANKLIN ELECTRIC DURANTE SU INSTALACION, PUEDE OCASIONAR, UN CHOQUE ELECTRICO, PELIGRO DE UN INCENDIO, OPERACION DEFECTUOSA E INCLUSO LA DESCOMPOSTURA DEL EQUIPO. LOS MANUALES DE INSTALACION Y PUESTA EN MARCHA DE LOS EQUIPOS, ESTAN DISPONIBLES CON LOS DISTRIBUIDORES, FABRICANTES DE BOMBAS O DIRECTAMENTE CON FRANKLIN ELECTRIC. PUEDE LLAMAR GRATUITAMENTE PARA MAYOR INFORMACION AL TELEFONO 800-348-2420.

## **ADVERTENCIA**

PUEDE OCURRIR UN CHOQUE ELECTRICO, SERIO O FATAL DEBIDO A UNA ERRONEA CONECCION DEL MOTOR, DE LOS TABLEROS ELECTRICOS, DE LA TUBERIA, DE CUALQUIER OTRA PARTE METALICA QUE ESTA CERCA DEL MOTOR O POR NO UTILIZAR UN CABLE PARA TIERRA DE CALIBRE IGUAL O MAYOR AL DE LA ALIMENTACION. PARA REDUCIR EL RIESGO DE CHOQUE ELECTRIC, DESCONECTAR LA ALIMENTACION ELECTRICA ANTES DE INICIAR A TRABAJAR EN EL SISTEMA HIDRAULICO. NO UTILIZAR ESTE MOTOR EN ALBERCAS O AREAS EN DONDE SE PRACTIQUE NATACION.



# 60 Hz, Single-Phase and Three-Phase

## SUBMERSIBLE MOTOR

### Application • Installation • Maintenance Manual

The submersible motor is a reliable, efficient and trouble-free means of powering a pump. Its needs for a long operational life are simple. They are:

1. A suitable operating environment
2. An adequate supply of electricity
3. An adequate flow of cooling water over the motor
4. An appropriate pump load

All considerations of application, installation, and maintenance of submersible motors relating to these four areas are presented in this manual. Franklin Electric's web page, [www.franklin-electric.com](http://www.franklin-electric.com), should be checked for the latest updates.

## Contents

### Motor Application

#### All Motors

Storage.....	3
Frequency of Starts.....	3
Mounting Position.....	3
Transformer Capacity.....	4
Effects of Torque.....	4
Use of Engine Driven Generators.....	5
Use of Check Valves.....	5
Well Diameters, Uncased, Top Feeding, Screens.....	6
Water Temperature and Flow.....	6
Flow Inducer Sleeve.....	6
Head Loss Past Motor.....	7
Hot Water Applications.....	7-8
Drawdown Seals.....	9
Grounding Control Boxes and Panels.....	9
Grounding Surge Arrestors.....	9
Control Box, Pumptec Products and Panel Environment.....	9
Equipment Grounding.....	9

#### Single-Phase Motors

3-Wire Control Boxes.....	10
2-Wire Motor Solid State Controls.....	10
QD Relays (Solid State).....	10
Cable Selection 2-Wire or 3-Wire.....	11
Two Different Cable Sizes.....	12

Single-Phase Motor Specifications.....	13
Single-Phase Motor Specifications with a "G" suffix.....	14
Single-Phase Motor Specifications 700 Series.....	14
Single-Phase Motor Fuse Sizing.....	15
Auxiliary Running Capacitors.....	16
Buck-Boost Transformers.....	16

#### Three-Phase Motors

Cable Selection - 60 °C Three-Wire.....	17-18
Cable Selection - 60 °C Six-Wire.....	19
Cable Selection - 75 °C Three-Wire.....	20-21
Cable Selection - 75 °C Six-Wire.....	22
Three-Phase Motor Specifications.....	23-31
Overload Protection.....	32
SubMonitor.....	33
Power Factor Correction.....	33
Three-Phase Starter Diagrams.....	34
Three-Phase Power Unbalance.....	35
Rotation and Current Unbalance.....	35
Three-Phase Motor Lead Identification.....	36
Phase Converters.....	36
Reduced Voltage Starters.....	37
Inline Booster Pump Systems.....	37-40
Variable Frequency Drive Submersible Motor Requirements.....	41-42

### Installation

#### All Motors

Submersible Motors - Dimensions.....	43
Tightening Lead Connector Jam Nut.....	44
Pump to Motor Coupling.....	44

Pump to Motor Assembly.....	44
Shaft Height and Free End Play.....	44
Submersible Leads and Cables.....	44

### Motor Maintenance

#### All Motors

System Troubleshooting.....	45-46
Preliminary Tests.....	47
Insulation Resistance.....	48
Resistance of Drop Cable.....	48

#### Single-Phase Motors and Controls

Identification of Cables.....	49
Single-Phase Control Boxes.....	49
Ohmmeter Tests.....	50
QD Control Box Parts.....	51
Integral hp Control Box Parts.....	52-53
Control Box Wiring Diagrams.....	54-58

### Electronic Application

#### Electronic Products

SubDrive/MonoDrive Overview.....	59
SubDrive/MonoDrive Generator Sizing.....	59
SubDrive/MonoDrive Ground Wire Location.....	59
SubDrive/MonoDrive Fuse/Circuit Breaker Sizing.....	60

SubDrive/MonoDrive Wire Sizing.....	60
SubDrive/MonoDrive Pressure Tank Sizing.....	61
SubDrive/MonoDrive Pressure Tank Pre-Charge.....	61

### Electronic Maintenance

#### Electronic Controls

Pumptec-Plus Troubleshooting During Installation.....	62
Pumptec-Plus and Pumptec After Installation.....	63
QD Pumptec and Pumptec Troubleshooting.....	64

SubDrive/MonoDrive Troubleshooting.....	65-70
SubMonitor Troubleshooting.....	71

### Abbreviations/Notes

Abbreviations.....	72
--------------------	----

Notes.....	73
------------	----

# All Motors

## MOTOR APPLICATION

### Storage

Franklin Electric submersible motors are a water-lubricated design. The fill solution consists of a mixture of deionized water and Propylene Glycol (a non-toxic antifreeze). The solution will prevent damage from freezing in temperatures to -40 °F (-40 °C); motors should be stored in areas that do not go below this temperature. The solution will partially freeze below 27 °F (-3 °C), but no damage occurs. Repeated freezing and thawing should be avoided to prevent possible loss of fill solution.

There may be an interchange of fill solution with well water during operation. Care must be taken with motors removed from wells during freezing conditions to prevent damage.

When the storage temperature does not exceed 100 °F (37 °C), storage time should be limited to two years. Where temperatures reach 100 °F to 130 °F, storage time should be limited to one year.

Loss of a few drops of liquid will not damage the motor as an excess amount is provided, and the filter check valve will allow lost liquid to be replaced by filtered well water upon installation. If there is reason to believe there has been a considerable amount of leakage, consult the factory for checking procedures.

### Frequency of Starts

The average number of starts per day over a period of months or years influences the life of a submersible pumping system. Excessive cycling affects the life of control components such as pressure switches, starters, relays, and capacitors. Rapid cycling can also cause motor spline damage, bearing damage, and motor overheating. All these conditions can lead to reduced motor life.

The pump size, tank size, and other controls should be selected to keep the starts per day as low as practical for longest life. The maximum number of starts per 24-hour period is shown in Table 3.

Motors should run a minimum of one minute to dissipate heat build up from starting current. Six inch and larger motors should have a minimum of 15 minutes between starts or starting attempts.

**Table 3 Number of Starts**

MOTOR RATING		MAXIMUM STARTS PER 24 HR PERIOD	
HP	KW	SINGLE-PHASE	THREE-PHASE
Up to 0.75	Up to 0.55	300	300
1 thru 5.5	0.75 thru 4	100	300
7.5 thru 30	5.5 thru 22	50	100*
40 and over	30 and over	-	100

\* Keeping starts per day within the recommended numbers provides the best system life. However, when used with a properly configured Reduced Voltage Starter (RVS) or Variable Frequency Drive (VFD), 7.5 thru 30 hp three-phase motors can be started up to 200 times per 24 hour period.

### Mounting Position

Franklin submersible motors are designed primarily for operation in the vertical, shaft-up position.

During acceleration, the pump thrust increases as its output head increases. In cases where the pump head stays below its normal operating range during start-up and full speed condition, the pump may create upward thrust. This creates upward thrust on the motor upthrust bearing. This is an acceptable operation for short periods at each start, but running continuously with upthrust will cause excessive wear on the upthrust bearing.

With certain additional restrictions as listed in this section and the Inline Booster Pump Systems sections of this manual, motors are also suitable for operation in positions from shaft-up to shaft-horizontal. As the mounting position becomes further from vertical and closer to horizontal, the probability of shortened thrust bearing life increases. For normal motor life expectancy with motor positions other than shaft-up, follow these recommendations:

1. Minimize the frequency of starts, preferably to fewer than 10 per 24-hour period. Six and eight inch motors should have a minimum of 20 minutes between starts or starting attempts
2. Do not use in systems which can run even for short periods at full speed without thrust toward the motor.

# All Motors

## MOTOR APPLICATION

### Transformer Capacity - Single-Phase or Three-Phase

Distribution transformers must be adequately sized to satisfy the kVA requirements of the submersible motor. When transformers are too small to supply the load, there is a reduction in voltage to the motor.

Table 4 references the motor horsepower rating, single-phase and three-phase, total effective kVA required, and the smallest transformer required for open or closed

three-phase systems. Open systems require larger transformers since only two transformers are used.

Other loads would add directly to the kVA sizing requirements of the transformer bank.

**Table 4 Transformer Capacity**

MOTOR RATING		TOTAL EFFECTIVE KVA REQUIRED	SMALLEST KVA RATING-EACH TRANSFORMER	
HP	KW		OPEN WYE OR DELTA 2- TRANSFORMERS	CLOSED WYE OR DELTA 3- TRANSFORMERS
1.5	1.1	3	2	1
2	1.5	4	2	1.5
3	2.2	5	3	2
5	3.7	7.5	5	3
7.5	5.5	10	7.5	5
10	7.5	15	10	5
15	11	20	15	7.5
20	15	25	15	10
25	18.5	30	20	10
30	22	40	25	15
40	30	50	30	20
50	37	60	35	20
60	45	75	40	25
75	55	90	50	30
100	75	120	65	40
125	93	150	85	50
150	110	175	100	60
175	130	200	115	70
200	150	230	130	75

**NOTE:** Standard kVA ratings are shown. If power company experience and practice allows transformer loading higher than standard, higher loading values may be used to meet total effective kVA required, provided correct voltage and balance is maintained.

### Effects of Torque

During starting of a submersible pump, the torque developed by the motor must be supported through the pump, delivery pipe or other supports. Most pumps rotate in the direction which causes unscrewing torque on right-handed threaded pipe or pump stages. All threaded joints, pumps, and other parts of the pump support system must be capable of withstanding the maximum torque repeatedly without loosening or breaking. Unscrewing joints will break electrical cable and may cause loss of the pump-motor unit.

To safely withstand maximum unscrewing torques with a minimum safety factor of 1.5, tightening all threaded joints to at least 10 lb-ft per motor horsepower is recommended (Table 4A). It may be necessary to tack or strap weld pipe joints on high horsepower pumps, especially at shallower settings.

**Table 4A Torque Required (Examples)**

MOTOR RATING		MINIMUM SAFE TORQUE-LOAD
HP	KW	
1 hp & Less	0.75 kW & Less	10 lb-ft
20 hp	15 kW	200 lb-ft
75 hp	55 kW	750 lb-ft
200 hp	150 kW	2000 lb-ft

# All Motors

## MOTOR APPLICATION

### Use of Engine Driven Generators - Single-Phase or Three-Phase

Table 5 lists minimum generator sizes based on typical 80 °C rise continuous duty generators, with 35% maximum voltage dip during starting, for Franklin's three-wire motors, single- or three-phase.

This is a general chart. The generator manufacturer should be consulted whenever possible, especially on larger sizes.

There are two types of generators available: externally and internally regulated. Most are externally regulated. They use an external voltage regulator that senses the output voltage. As the voltage dips at motor start-up, the regulator increases the output voltage of the generator.

Internally regulated (self-excited) generators have an extra winding in the generator stator. The extra winding senses the output current to automatically adjust the output voltage.

Generators must be sized to deliver at least 65% of the rated voltage during starting to ensure adequate starting torque. Besides sizing, generator frequency is important as the motor speed varies with the frequency (Hz). Due to pump affinity laws, a pump running at 1 to 2 Hz below motor nameplate frequency design will not meet its performance curve. Conversely, a pump running at 1 to 2 Hz above may trip overloads.

#### Generator Operation

Always start the generator before the motor is started and always stop the motor before the generator is shut down. The motor thrust bearing may be damaged if the generator is allowed to coast down with the motor running. This same condition occurs when the generator is allowed to run out of fuel.

Follow generator manufacturer's recommendations for de-rating at higher elevations or using natural gas.

**NOTE:** Using the minimum rating or sized generator acts as a soft start to the motor. No additional voltage reduction is allowed.

**CAUTION:** Do not use a Reduced Voltage Starter with a minimum sized generator. Both items drop the output voltage and combining these items causes the potential for severe motor damage and failure due to low voltage.

### Use of Check Valves

It is recommended that one or more check valves always be used in submersible pump installations. If the pump does not have a built-in check valve, a line check valve should be installed in the discharge line within 25 feet of the pump and below the draw down level of the water supply. For deeper settings, check valves should be installed per the manufacturer's recommendations. More than one check valve may be required, but more than the recommended number of check valves should not be used.

Swing type check valves are **not** acceptable and should never be used with submersible motors/pumps. Swing type check valves have a slower reaction time which can cause water hammer (see next page). Internal pump check valves or spring loaded check valves close quickly and help eliminate water hammer.

Check valves are used to hold pressure in the system when the pump stops. They also prevent backspin, water hammer and upthrust. Any of these can lead to early pump or motor failure.

**NOTE:** Only positive sealing check valves should be used in submersible installations. Although drilling the check valves or using drain-back check valves may prevent back spinning, they create upthrust and water hammer problems.

**A. Backspin** - With no check valve or a failed check valve, the water in the drop pipe and the water in the system can flow down the discharge pipe when the motor stops. This can cause the pump to rotate in a reverse direction. If the motor is started while it is backspinning, an excessive force is placed across the pump-

**Table 5 Engine Driven Generators**

**NOTE:** This chart applies to 3-wire or 3-phase motors. For best starting of 2-wire motors, the minimum generator rating is 50% higher than shown.

MOTOR RATING		MINIMUM RATING OF GENERATOR	
HP	KW	EXTERNALLY REGULATED	
		KW	KVA
1/3	0.25	1.5	1.9
1/2	0.37	2	2.5
3/4	0.55	3	3.8
1	0.75	4	5.0
1.5	1.1	5	6.25
2	1.5	7.5	9.4
3	2.2	10	12.5
5	3.7	15	18.75
7.5	5.5	20	25.0
10	7.5	30	37.5
15	11	40	50
20	15	60	75
25	18.5	75	94
30	22	100	125
40	30	100	125
50	37	150	188
60	45	175	220
75	55	250	313
100	75	300	375
125	93	375	469
150	110	450	563
175	130	525	656
200	150	600	750

**WARNING:** To prevent accidental electrocution, automatic or manual transfer switches must be used any time a generator is used as standby or back up on power lines. Contact power company for use and approval.

motor assembly that can cause impeller damage, motor or pump shaft breakage, excessive bearing wear, etc.

- B. Upthrust** - With no check valve, a leaking check valve, or drilled check valve, the unit starts under a zero head condition. This causes an uplifting or upthrust on the impeller-shaft assembly in the pump. This upward movement carries across the pump-motor coupling and creates an upthrust condition in the motor. Repeated upthrust can cause premature failure of both the pump and the motor.
- C. Water Hammer** - If the lowest check valve is more than 30 feet above the standing (lowest static) water level, or a lower check valve leaks and the check valve above holds, a vacuum is created in the discharge piping. On the next pump start, water moving at very high velocity fills the void and strikes the closed check valve and the stationary water in the pipe above it, causing a hydraulic shock. This shock can split pipes, break joints and damage the pump and/or motor. Water hammer can often be heard or felt. When discovered, the system should be shut down and the pump installer contacted to correct the problem.
- D. VFD Controlled Pump** - Most standard spring-loaded check valves are not designed for variable flow conditions resulting in premature wear and noisy conditions that can transfer thru the system piping. For best service life and quietest operation use only check valves that are especially designed for variable flow conditions. The valve brands available on the market are generally marked as "VFD compatible".



# All Motors

## MOTOR APPLICATION

### Wells – Large Diameter, Uncased, Top Feeding, and Screened Sections

Franklin Electric submersible motors are designed to operate with a cooling flow of water over and around the full length of the motor.

If the pump installation does not provide the minimum flow shown in Table 6, a flow inducer sleeve (flow sleeve) must be used. The conditions requiring a flow sleeve are:

- Well diameter is too large to meet Table 6 flow requirements
- Pump is in an open body of water
- Pump is in a rock well or below the well casing
- The well is “top-feeding” (a.k.a. cascading)
- Pump is set in or below screens or perforations

### Water Temperature and Flow

Franklin Electric’s standard submersible motors, except Hi-Temp designs (see note below), are designed to operate up to maximum service factor horsepower in water up to 86 °F (30 °C). A flow of 0.25 ft/s for 4” motors rated 3 hp and higher, and 0.5 ft/s for 6” and 8” motors is required for proper cooling. Table 6 shows minimum flow rates, in gpm, for various well diameters and motor sizes.

If a standard motor is operated in water over 86 °F (30 °C), water flow past the motor must be increased to maintain safe motor operating temperatures. See HOT WATER APPLICATIONS on page 7.

**NOTE:** Small 4” Motors (2Hp & Smaller) do not have a required minimum flow, except flow must be greater than zero flow.

**NOTE:** Franklin Electric offers a line of Hi-Temp motors designed to operate in water at higher temperatures or lower flow conditions. Consult factory for details.

**Table 6 Required Cooling Flow**

MINIMUM GPM REQUIRED FOR MOTOR COOLING IN WATER UP TO 86 °F (30 °C)					
CASING OR SLEEVE ID INCHES (MM)	4” MOTOR (3-10 HP) 0.25 FT/S GPM (L/M)	6” MOTOR 0.50 FT/S GPM (L/M)	8” MOTOR 0.50 FT/S GPM (L/M)	10” MOTOR FT/S GPM (L/M)	12” MOTOR FT/S GPM (L/M)
4 (102)	1.2 (4.5)	-	-		
5 (127)	7 (26.5)	-	-		
6 (152)	13 (49)	9 (34)	-		
7 (178)	20 (76)	25 (95)	-		
8 (203)	30 (114)	45 (170)	10 (40)		
10 (254)	50 (189)	90 (340)	55 (210)		
12 (305)	80 (303)	140 (530)	110 (420)		
14 (356)	110 (416)	200 (760)	170 (645)		
16 (406)	150 (568)	280 (1060)	245 (930)		

0.25 ft/s = 7.62 cm/sec 0.50 ft/s = 15.24 cm/sec

1 inch = 2.54 cm

### Flow Inducer Sleeve

If the flow rate is less than specified, then a flow inducer sleeve must be used. A flow sleeve is always required in an open body of water. FIG. 1 shows a typical flow inducer sleeve construction.

**EXAMPLE:** A 6” motor and pump that delivers 60 gpm will be installed in a 10” well.

From Table 6, 90 gpm would be required to maintain proper cooling. In this case adding an 8” or smaller flow sleeve provides the required cooling.

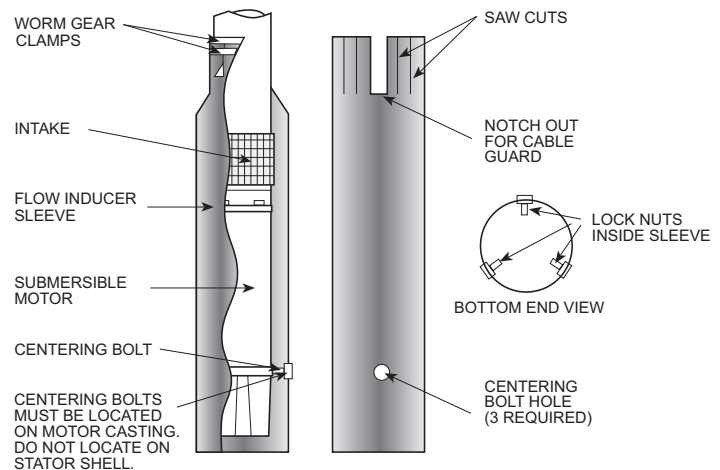

**FIG. 1**

# All Motors

## MOTOR APPLICATION

### Head Loss From Flow Past Motor

Table 7 lists the approximate head loss due to flow between an average length motor and smooth casing or flow inducer sleeve.

**Table 7 Head Loss in Feet (Meters) at Various Flow Rates**

MOTOR DIAMETER		4"	4"	4"	6"	6"	6"	8"	8"
CASING ID IN INCHES (MM)		4 (102)	5 (127)	6 (152)	6 (152)	7 (178)	8 (203)	8.1 (206)	10 (254)
Flow Rate in gpm (l/m)	25 (95)	0.3 (.09)							
	50 (189)	1.2 (.37)							
	100 (378)	4.7 (1.4)	0.3 (.09)		1.7 (.52)				
	150 (568)	10.2 (3.1)	0.6 (.18)	0.2 (.06)	3.7 (1.1)				
	200 (757)		1.1 (.34)	0.4 (.12)	6.3 (1.9)	0.5 (.15)		6.8 (2.1)	
	250 (946)		1.8 (.55)	0.7 (.21)	9.6 (2.9)	0.8 (.24)		10.4 (3.2)	
	300 (1136)		2.5 (.75)	1.0 (.30)	13.6 (4.1)	1.2 (.37)	0.2 (.06)	14.6 (4.5)	
	400 (1514)				23.7 (7.2)	2.0 (.61)	0.4 (.12)	24.6 (7.5)	
	500 (1893)					3.1 (.94)	0.7 (.21)	37.3 (11.4)	0.6 (0.2)
	600 (2271)					4.4 (1.3)	1.0 (.30)	52.2 (15.9)	0.8 (0.3)
	800 (3028)								1.5 (0.5)
1000 (3785)								2.4 (0.7)	

### Hot Water Applications (Standard Motors)

Franklin Electric offers a line of Hi-Temp motors which are designed to operate in water with various temperatures up to 194 °F (90 °C) without increased flow. When a standard pump-motor operates in water hotter than 86 °F (30 °C), a flow rate of at least 3 ft/s is required. When selecting the motor to drive a pump in over 86 °F (30 °C) water, the motor horsepower must be de-rated per the following procedure.

- Using Table 7A, determine pump gpm required for different well or sleeve diameters. If necessary, add a flow sleeve to obtain at least 3 ft/s flow rate.

**Table 7A Minimum gpm (l/m) Required for 3 ft/s (.91 m/sec) Flow Rate**

CASING OR SLEEVE ID		4" HIGH THRUST MOTOR		6" MOTOR		8" MOTOR	
INCHES	(MM)	GPM	(L/M)	GPM	(L/M)	GPM	(L/M)
4	(102)	15	(57)				
5	(127)	80	(303)				
6	(152)	160	(606)	52	(197)		
7	(178)			150	(568)		
8	(203)			260	(984)	60	(227)
10	(254)			520	(1970)	330	(1250)
12	(305)					650	(2460)
14	(356)					1020	(3860)
16	(406)					1460	(5530)

Continued on next page

# All Motors

## MOTOR APPLICATION

- Determine pump horsepower required from the pump manufacturer's curve.

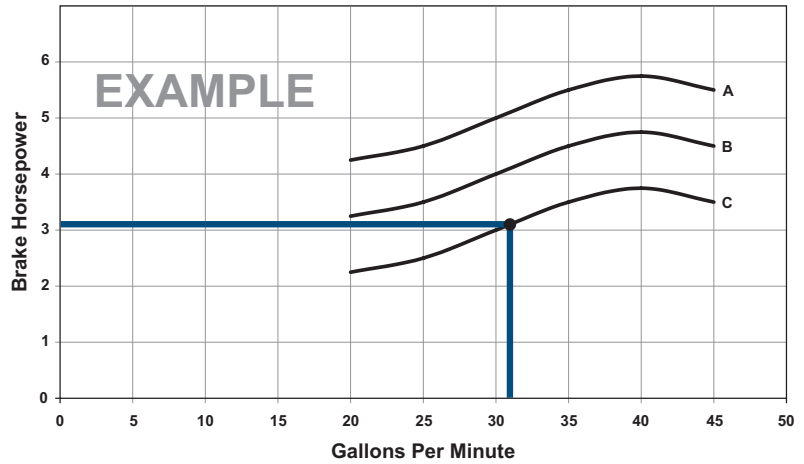

FIG. 2 MANUFACTURER'S PUMP CURVE

- Multiply the pump horsepower required by the heat factor multiplier from Table 8.

Table 8 Heat Factor Multiplier at 3 ft/s (.91 m/sec) Flow Rate

MAXIMUM WATER TEMPERATURE	1/3 - 5 HP .25 - 3.7 KW	7 1/2 - 30 HP 5.5 - 22 KW	OVER 30 HP OVER 22 KW
140 °F (60 °C)	1.25	1.62	2.00
131 °F (55 °C)	1.11	1.32	1.62
122 °F (50 °C)	1.00	1.14	1.32
113 °F (45 °C)	1.00	1.00	1.14
104 °F (40 °C)	1.00	1.00	1.00
95 °F (35 °C)	1.00	1.00	1.00

- Select a rated hp motor on Table 8A whose Service Factor Horsepower is at least the value calculated in Item 3.

Table 8A Service Factor Horsepower

HP	KW	SFHP	HP	KW	SFHP	HP	KW	SFHP	HP	KW	SFHP
1/3	0.25	0.58	3	2.2	3.45	25	18.5	28.75	100	75	115.00
1/2	0.37	0.80	5	3.7	5.75	30	22.0	34.50	125	93	143.75
3/4	0.55	1.12	7.5	5.5	8.62	40	30.0	46.00	150	110	172.50
1	0.75	1.40	10	7.5	11.50	50	37.0	57.50	175	130	201.25
1.5	1.10	1.95	15	11.0	17.25	60	45.0	69.00	200	150	230.00
2	1.50	2.50	20	15.0	23.00	75	55.0	86.25			

## Hot Water Applications - Example

**EXAMPLE:** A 6" pump end requiring 39 hp input will pump 124 °F water in an 8" well at a delivery rate of 140 gpm. From Table 7A, a 6" flow sleeve will be required to increase the flow rate to at least 3 ft/s.

Using Table 8, the 1.62 heat factor multiplier is selected because the hp required is over 30

hp and water temperature is above 122 °F. Multiply 39 hp x 1.62 (multiplier), which equals 63.2 hp. This is the minimum rated service factor horsepower usable at 39 hp in 124 °F. Using Table 8A, select a motor with a rated service factor horsepower above 63.2 hp. A 60 hp motor has a service factor horsepower of 69, so a 60 hp motor may be used.

# All Motors

## MOTOR APPLICATION

### Drawdown Seals

Allowable motor temperature is based on atmospheric pressure or higher surrounding the motor. “Drawdown seals,” which seal the well to the pump above its intake to

maximize delivery are not recommended, since the suction created can be lower than atmospheric pressure.

### Grounding Control Boxes and Panels

The National Electrical Code requires that the control box or panel-grounding terminal always be connected to supply ground. If the circuit has no grounding conductor and no metal conduit from the box to supply panel, use a wire at least as large as line conductors and connect as required by the National Electrical Code, from the grounding terminal to the electrical supply ground.

**WARNING:** Failure to ground the control frame can result in a serious or fatal electrical shock hazard.

### Grounding Surge Arrestors

An above ground surge arrestor must be grounded, metal to metal, all the way to the lowest draw down water strata for the surge arrestor to be effective. **GROUNDING THE ARRESTOR TO THE SUPPLY GROUND OR TO A DRIVEN GROUND ROD PROVIDES LITTLE OR NO SURGE PROTECTION FOR THE MOTOR.**

### Control Box, Pumptec Products, and Panel Environment

Franklin Electric control boxes, Pumptec products and three-phase panels meet UL requirements for NEMA Type 3R enclosures. They are suitable for indoor and outdoor applications within temperatures of +14 °F (-10 °C) to 122 °F (50 °C). Operating control boxes below +14 °F can cause reduced starting torque and loss of overload protection when overloads are located in control boxes.

Control boxes, Pumptec products, and three-phase panels should never be mounted in direct sunlight or high temperature locations. This will cause shortened capacitor life (where applicable) and unnecessary tripping of overload protectors. A ventilated

enclosure painted white to reflect heat is recommended for an outdoor, high temperature location.

A damp well pit, or other humid location, accelerates component failure from corrosion.

Control boxes with voltage relays are designed for vertical upright mounting only. Mounting in other positions will affect the operation of the relay.

### Equipment Grounding

**WARNING:** Serious or fatal electrical shock may result from failure to connect the motor, control enclosures, metal plumbing, and all other metal near the motor or cable to the power supply ground terminal using wire no smaller than motor cable wires.

The primary purpose of grounding the metal drop pipe and/or metal well casing in an installation is safety. It is done to limit the voltage between nonelectrical (exposed metal) parts of the system and ground, thus minimizing dangerous shock hazards. Using wire at least the size of the motor cable wires provides adequate current-carrying capability for any ground fault that might occur. It also provides a low resistance path to ground, ensuring that the current to ground will be large enough to trip any overcurrent device designed to detect faults (such as a ground fault circuit interrupter, or GFCI).

Normally, the ground wire to the motor would provide the primary path back to the power supply ground for any ground fault. There are conditions, however, where the ground wire connection could become compromised. One such example would be the case where the water in the well is abnormally corrosive or aggressive. In this example, a grounded metal drop pipe or casing would then become the primary path to ground.

However, the many installations that now use plastic drop pipes and/or casings require further steps to be taken for safety purposes, so that the water column itself does not become the conductive path to ground.

When an installation has abnormally corrosive water AND the drop pipe or casing is plastic, Franklin Electric recommends the use of a GFCI with a 10 mA set-point. In this case, the motor ground wire should be routed through the current-sensing device along with the motor power leads. Wired this way, the GFCI will trip only when a ground fault has occurred AND the motor ground wire is no longer functional.

# Single-Phase Motors

## MOTOR APPLICATION

### 3-Wire Control Boxes

Single-phase three-wire submersible motors require the use of control boxes. Operation of motors without control boxes or with incorrect boxes can result in motor failure and voids warranty.

Control boxes contain starting capacitors, a starting relay, and, in some sizes, overload protectors, running capacitors, and contactors.

Ratings through 1 hp may use either a Franklin Electric solid state QD or a potential (voltage) type starting relay, while larger ratings use potential relays.

#### Potential (Voltage) Relays

Potential relays have normally closed contacts. When power is applied, both start and main motor windings are energized, and the motor starts. At this instant, the voltage across the start winding is relatively low and not enough to open the contacts of the relay.

### 2-Wire Motor Solid State Controls

#### BIAC Switch Operation

When power is applied, the bi-metal switch contacts are closed, so the triac is conducting and energizes the start winding. As rpm increases, the voltage in the sensor coil generates heat in the bi-metal strip, causing the bi-metal strip to bend and open the switch circuit. This removes the starting winding and the motor continues to run on the main winding alone.

Approximately 5 seconds after power is removed from the motor, the bi-metal strip cools sufficiently to return to its closed position, and the motor is ready for the next start cycle. If, during operation, the motor speed drops, the lowered voltage in the sensor coil allows the bi-metal contacts to close, and bring the motor back to operating speed.

#### Rapid Cycling

The BIAC starting switch will reset within approximately 5 seconds after the motor is stopped. If an attempt is made to restart the motor before the starting switch has reset, the motor may not start; however, there will be current in the main winding until the overload protector interrupts the circuit. The time for the protector to reset is longer

#### QD Relays (Solid State)

There are two elements in the relay: a reed switch and a triac. The reed switch consists of two tiny rectangular blade-type contacts, which bend under magnetic flux. It is hermetically sealed in glass and is located within a coil, which conducts line current. When power is supplied to the control box, the main winding current passing through the coil immediately closes the reed switch contacts. This turns on the triac, which supplies voltage to the start winding, thus starting the motor.

Once the motor is started, the operation of the QD relay is an interaction between the triac, the reed switch, and the motor windings. The solid state switch senses motor

As the motor accelerates, the increasing voltage across the start winding (and the relay coil) opens the relay contacts. This opens the starting circuit and the motor continues to run on the main winding alone, or the main plus run capacitor circuit. After the motor is started the relay contacts remain open.

**CAUTION:** The control box and motor are two pieces of one assembly. Be certain that the control box and motor hp and voltage match. Since a motor is designed to operate with a control box from the same manufacturer, we can promise warranty coverage only when a Franklin control box is used with a Franklin motor.

than the reset of the starting switch. Therefore, the start switch will have closed and the motor will operate.

A waterlogged tank will cause fast cycling. When a waterlogged condition does occur, the user will be alerted to the problem during the off time (overload reset time) since the pressure will drop drastically. When the waterlogged tank condition is detected, the condition should be corrected to prevent nuisance tripping of the overload protector.

#### Bound Pump (Sandlocked)

When the motor is not free to turn, as with a sandlocked pump, the BIAC switch creates a “reverse impact torque” in the motor in either direction. When the sand is dislodged, the motor will start and operate in the correct direction.

**CAUTION:** Restarting the motor within 5 seconds after power is removed may cause the motor overload to trip.

speed through the changing phase relationship between start winding current and line current. As the motor approaches running speed, the phase angle between the start current and the line current becomes nearly in phase. At this point, the reed switch contacts open, turning off the triac. This removes voltage from the start winding and the motor continues to run on the main winding only. With the reed switch contacts open and the triac turned off, the QD relay is ready for the next starting cycle.

# Single-Phase Motors

## MOTOR APPLICATION

### 2- or 3-Wire Cable, 60 Hz (Service Entrance to Motor - Maximum Length In Feet)

Table 11

60 °C

MOTOR RATING			60 °C INSULATION - AWG COPPER WIRE SIZE													
VOLTS	HP	KW	14	12	10	8	6	4	3	2	1	0	00	000	0000	
115	1/2	.37	100	160	250	390	620	960	1190	1460	1780	2160	2630	3140	3770	
	1/2	.37	400	650	1020	1610	2510	3880	4810	5880	7170	8720				
230	3/4	.55	300	480	760	1200	1870	2890	3580	4370	5330	6470	7870			
	1	.75	250	400	630	990	1540	2380	2960	3610	4410	5360	6520			
	1.5	1.1	190	310	480	770	1200	1870	2320	2850	3500	4280	5240			
	2	1.5	150	250	390	620	970	1530	1910	2360	2930	3620	4480			
	3	2.2	<b>120</b>	190	300	470	750	1190	1490	1850	2320	2890	3610			
	5	3.7	0	0	<b>180</b>	280	450	710	890	1110	1390	1740	2170	2680		
	7.5	5.5	0	0	0	<b>200</b>	310	490	610	750	930	1140	1410	1720		
	10	7.5	0	0	0	0	<b>250</b>	390	490	600	750	930	1160	1430	1760	
	15	11	0	0	0	0	<b>170</b>	<b>270</b>	340	430	530	660	820	1020	1260	

Table 11A

75 °C

MOTOR RATING			75 °C INSULATION - AWG COPPER WIRE SIZE												
VOLTS	HP	KW	14	12	10	8	6	4	3	2	1	0	00	000	0000
115	1/2	.37	100	160	250	390	620	960	1190	1460	1780	2160	2630	3140	3770
	1/2	.37	400	650	1020	1610	2510	3880	4810	5880	7170	8720			
230	3/4	.55	300	480	760	1200	1870	2890	3580	4370	5330	6470	7870	9380	
	1	.75	250	400	630	990	1540	2380	2960	3610	4410	5360	6520	7780	9350
	1.5	1.1	190	310	480	770	1200	1870	2320	2850	3500	4280	5240	6300	7620
	2	1.5	150	250	390	620	970	1530	1910	2360	2930	3620	4480	5470	6700
	3	2.2	<b>120</b>	190	300	470	750	1190	1490	1850	2320	2890	3610	4470	5550
	5	3.7	0	<b>110</b>	180	280	450	710	890	1110	1390	1740	2170	2680	3330
	7.5	5.5	0	0	<b>120</b>	200	310	490	610	750	930	1140	1410	1720	2100
	10	7.5	0	0	0	<b>160</b>	250	390	490	600	750	930	1160	1430	1760
	15	11	0	0	0	0	<b>170</b>	270	340	430	530	660	820	1020	1260

1 Foot = .3048 Meter

Lengths in **BOLD** only meet the US National Electrical Code ampacity requirements for individual conductors 60 °C or 75 °C in free air or water, not in magnetic enclosures, conduit or direct buried.

Lengths NOT in bold meet the NEC ampacity requirements for either individual conductors or jacketed 60 °C or 75 °C cable and can be in conduit or direct buried. Flat molded and web/ribbon cable are considered jacketed cable.

If any other cable is used, the NEC and local codes should be observed.

Cable lengths in Tables 11 & 11A allow for a 5% voltage drop running at maximum nameplate amperes. If 3% voltage drop is desired, multiply Table 11 and 11A lengths by 0.6 to get maximum cable length.

The portion of the total cable length, which is between the supply and single-phase control box with a line contactor, should not exceed 25% of total maximum allowable to ensure reliable contactor operation. Single-phase control boxes without line contactors may be connected at any point in the total cable length.

Tables 11 & 11A are based on copper wire. If aluminum wire is used, it must be two sizes larger than copper wire and oxidation inhibitors must be used on connections.

**EXAMPLE:** If Tables 11 & 11A call for #12 copper wire, #10 aluminum wire would be required.

Contact Franklin Electric for 90 °C cable lengths.

See pages 15, 50, and 51 for applications using 230 V motors on 208 V power systems.

# Single-Phase Motors

## MOTOR APPLICATION

### Two or More Different Cable Sizes Can Be Used

Depending on the installation, any number of combinations of cable may be used.

For example, in a replacement/upgrade installation, the well already has 160 feet of buried #10 cable between the service entrance and the wellhead. A new 3 hp, 230 Volt, single-phase motor is being installed to replace a smaller motor. The question is: Since there is already 160 feet of #10 AWG installed, what size cable is required in the well with a 3 hp, 230 Volt, single-phase motor setting at 310 feet?

From Tables 11 and 11A, a 3 hp motor can use up to 300 feet of #10 AWG cable.

The application has 160 feet of #10 AWG copper wire installed.

Using the formula below, 160 feet (actual) ÷ 300 feet (max allowable) is equal to 0.533. This means 53.3% (0.533 x 100) of the allowable voltage drop or loss, which is allowed between the service entrance and the motor, occurs in this wire. This leaves us 46.7% (1.00 - 0.533 = 0.467) of some other wire size to use in the remaining 310 feet “down hole” wire run.

The table shows #8 AWG copper wire is good for 470 feet. Using the formula again, 310 feet (used) ÷ 470 feet (allowed) = 0.660; adding this to the 0.533 determined earlier; 0.533 + 0.660 = 1.193. This combination is greater than 1.00, so the voltage drop will not meet US National Electrical Code recommendations.

Tables 11 and 11A show #6 AWG copper wire is good for 750 feet. Using the formula, 310 ÷ 750 = 0.413, and using these numbers, 0.533 + 0.413 = 0.946, we find this is less than 1.00 and will meet the NEC recommended voltage drop.

This works for two, three or more combinations of wire and it does not matter which size wire comes first in the installation.

$$\text{Formula: } \frac{\text{Actual Length}}{\text{Max Allowed}} + \frac{\text{Actual Length}}{\text{Max Allowed}} = 1.00$$

### EXAMPLE: 3 hp, 230 Volt, Single-Phase Motor

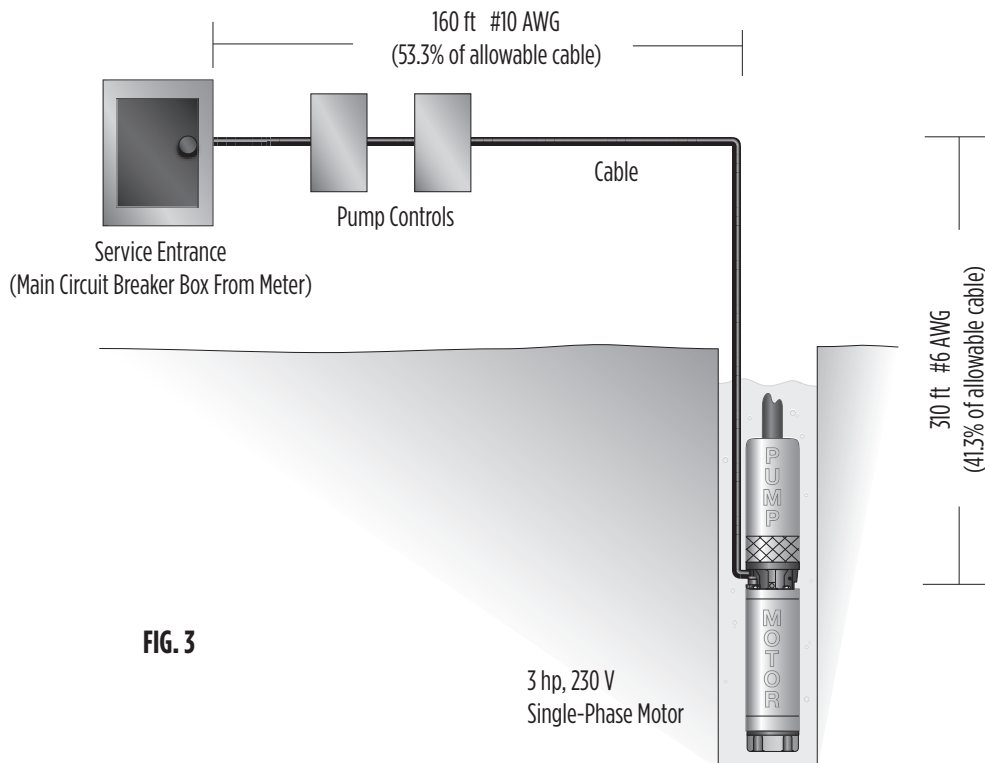

FIG. 3

# Single-Phase Motors

## MOTOR APPLICATION

**Table 13 Single-Phase Motor Specifications (60 Hz) 3450 rpm**

TYPE	MOTOR MODEL PREFIX	RATING					FULL LOAD		MAXIMUM LOAD		WINDING (1) RES. IN OHMS M=MAIN RES. S=START RES.	EFFICIENCY %		POWER FACTOR %		LOCKED ROTOR AMPS	KVA CODE
		HP	KW	VOLTS	HZ	S.F.	(2) AMPS	WATTS	(2) AMPS	WATTS		S.F.	F.L.	S.F.	F.L.		
4" 2-WIRE	244504	1/2	0.37	115	60	1.6	10.0	670	12.0	960	1.0-1.3	62	56	73	58	64.4	R
	244505	1/2	0.37	230	60	1.6	5.0	670	6.0	960	4.2-5.2	62	56	73	58	32.2	R
	244507	3/4	0.55	230	60	1.5	6.8	940	8.0	1310	3.0-3.6	64	59	74	62	40.7	N
	244508	1	0.75	230	60	1.4	8.2	1210	10.4	1600	2.2-2.7	65	62	74	63	48.7	N
	244309	1.5	1.1	230	60	1.3	10.6	1770	13.1	2280	1.5-2.1	64	63	83	76	66.2	M
4" 3-WIRE	214504	1/2	0.37	115	60	1.6	Y10.0 B10.0 R0	670	Y12.0 B12.0 R0	960	M1.0-1.3 S4.1-5.1	62	56	73	58	50.5	M
	214505	1/2	0.37	230	60	1.6	Y5.0 B5.0 R0	670	Y6.0 B6.0 R0	960	M4.2-5.2 S16.7-20.5	62	56	73	58	23	M
	214507	3/4	0.55	230	60	1.5	Y6.8 B6.8 R0	940	Y8.0 B8.0 R0	1310	M3.0-3.6 S10.7-13.1	64	59	74	62	34.2	M
	214508	1	0.75	230	60	1.4	Y8.2 B8.2 R0	1210	Y10.4 B10.4 R0	1600	M2.2-2.7 S9.9-12.1	65	62	74	63	41.8	L
4" 3-WIRE W/CRC CB	214505	1/2	0.37	230	60	1.6	Y3.2 B3.7 R2.0	655	Y4.3 B4.0 R2.0	890	M4.2-5.2 S16.7-20.5	67	57	90	81	23	M
	214507	3/4	0.55	230	60	1.5	Y4.4 B5.0 R3.2	925	Y5.7 B5.2 R3.1	1220	M3.0-3.6 S10.7-13.1	69	60	92	84	34.2	M
	214508	1	0.75	230	60	1.4	Y5.6 B5.7 R3.4	1160	Y8.1 B6.2 R3.3	1490	M2.2-2.7 S9.9-12.1	70	64	92	86	41.8	L
4" 3-WIRE	214508 W/1- 1.5 CB	1	0.75	230	60	1.4	Y6.6 B6.6 R1.3	1130	Y8.0 B7.9 R1.3	1500	M2.2-2.7 S9.9-12.1	70	66	82	72	43	L
	224300	1.5	1.1	230	60	1.3	Y10.0 B9.9 R1.3	1620	Y11.5 B11.0 R1.3	2080	M1.7-2.1 S7.5-9.2	70	69	85	79	51.4	J
	224301	2	1.5	230	60	1.25	Y10.0 B9.3 R2.6	2025	Y13.2 B11.9 R2.6	2555	M1.8-2.3 S5.5-7.2	73	74	95	94	53.1	G
	224302 (3)	3	2.2	230	60	1.15	Y14.0 B11.2 R6.1	3000	Y17.0 B12.6 R6.0	3400	M1.1-1.4 S4.0-4.8	75	75	99	99	83.4	H
	224303 (4)	5	3.7	230	60	1.15	Y23.0 B15.9 R11.0	4830	Y27.5 B19.1 R10.8	5500	M.71-.82 S1.8-2.2	78	77	100	100	129	G
6"	226110 (5)	5	3.7	230	60	1.15	Y23.0 B14.3 R10.8	4910	Y27.5 B17.4 R10.5	5570	M.55-.68 S1.3-1.7	77	76	100	99	99	E
	226111	7.5	5.5	230	60	1.15	Y36.5 B34.4 R5.5	7300	Y42.1 B40.5 R5.4	8800	M.36-.50 S.88-1.1	73	74	91	90	165	F
	226112	10	7.5	230	60	1.15	Y44.0 B39.5 R9.3	9800	Y51.0 B47.5 R8.9	11300	M.27-.33 S.80-.99	76	77	96	96	204	E
	226113	15	11	230	60	1.15	Y62.0 B52.0 R17.5	13900	Y75.0 B62.5 R16.9	16200	M.17-.22 S.68-.93	79	80	97	98	303	E

- (1) M = Main winding = yellow to black  
S = Start winding = yellow to red
- (2) Y = Yellow lead - line amps  
B = Black lead - main winding amps  
R = Red lead - start or auxiliary winding amps
- (3) Control Boxes date coded 02C and older have **35 MFD** run capacitors. Current values should be Y14.0 @ FL and Y17.0 @ Max Load.  
B12.2      B14.5  
R4.7      R4.5

- (4) Control Boxes date coded 01M and older have **60 MFD** run capacitors and the current values on a 4" motor will be Y23.0 @ FL - Y27.5 @ Max Load.  
B19.1      B23.2  
R8.0      R7.8
- (5) Control Boxes date coded 01M and older have **60 MFD** run capacitors and the current values on a 6" motor will be Y23.0 @ FL - Y27.5 @ Max Load.  
B18.2      B23.2  
R8.0      R7.8



# Single-Phase Motors

## MOTOR APPLICATION

**Table 13 Single-Phase Motor Specifications (60 Hz) with a "G" suffix (i.e., 2445059004G) having a date code of 17X14 or newer**

TYPE	MOTOR MODEL PREFIX	RATING					FULL LOAD		MAXIMUM LOAD		(1) LINE-TO-LINE RES. IN OHMS	EFFICIENCY %		POWER FACTOR %		LOCKED ROTOR AMPS	KVA CODE
		HP	KW	VOLTS	HZ	S.F.	(2) AMPS	WATTS	(2) AMPS	WATTS	M=MAIN RES. S=START RES.	S.F.	F.L.	S.F.	F.L.		
4" 2-WIRE	244504	1/2	0.37	115	60	1.6	10.0	660	12.0	1000	1.1-1.5	60	56	78	64	58.8	P
	244505	1/2	0.37	230	60	1.6	5.0	660	6.0	1000	4.7-5.8	60	56	78	64	28.5	P
	244507	3/4	0.55	230	60	1.5	6.8	925	8.0	1350	3.3-4.1	62	60	79	68	36.9	N
	244508	1	0.75	230	60	1.4	8.2	1215	10.4	1630	2.4-3.0	64	62	77	67	47.6	M
	244309	1.5	1.1	230	60	1.3	10.3	1690	13.1	2170	1.8-2.2	67	66	81	75	62.0	L
4" 3-WIRE	214504	1/2	0.37	115	60	1.6	Y10.0 B10.0 R0	660	Y12.0 B12.0 R0	1000	M1.1-1.5 S4.3-5.3	60	56	78	64	44.1	M
	214505	1/2	0.37	230	60	1.6	Y5.0 B5.0 R0	660	Y6.0 B6.0 R0	1000	M4.7-5.8 S17.5-21.5	60	56	78	64	20.6	M
	214507	3/4	0.55	230	60	1.5	Y6.8 B6.8 R0	925	Y8.0 B8.0 R0	1350	M3.3-4.1 S11.2-13.8	62	60	79	68	29.7	L
	214508	1	0.75	230	60	1.4	Y8.2 B8.2 R0	1215	Y10.4 B10.4 R0	1630	M2.4-3.0 S10.2-12.6	64	62	77	67	35.9	K
4" 3-WIRE W/CRC	214505	1/2	0.37	230	60	1.6	Y3.2 B3.7 R2.0	620	Y4.3 B4.0 R2.0	860	M4.7-5.8 S17.5-21.5	69	60	97	93	20.6	M
	214507	3/4	0.55	230	60	1.5	Y4.4 B5.0 R3.2	885	Y5.7 B5.2 R3.1	1185	M3.3-4.1 S11.2-13.8	71	63	99	98	29.7	L
	214508	1	0.75	230	60	1.4	Y5.6 B5.7 R3.4	1135	Y8.1 B6.2 R3.3	1455	M2.4-3.0 S10.2-12.6	72	66	96	93	35.9	K
4" 3-WIRE	214508 W/1-1.5 CB	1	0.75	230	60	1.4	Y6.6 B6.6 R2.0	1150	Y8.0 B7.4 R1.9	1460	M2.4-3.0 S10.2-12.6	71	65	89	85	41.7	L
	224300	1.5	1.1	230	60	1.3	Y10.0 B9.3 R1.9	1540	Y11.5 B10.8 R1.9	1980	M1.9-2.4 S6.8-8.3	73	73	90	87	49.0	J
	224301	2	1.5	230	60	1.25	Y10.0 B8.8 R2.6	1985	Y13.2 B12.0 R2.5	2535	M1.8-2.3 S5.6-6.9	74	75	96	95	51.0	G
	224302	3	2.2	230	60	1.15	Y12.8 B8.7 R6.1	2930	Y17.0 B13.2 R5.8	3350	M1.2-1.5 S3.2-3.9	77	76	98	98	84.0	H
	224303	5	3.7	230	60	1.15	Y20.5 B13.5 R10.5	4740	Y27.5 B21.0 R10.0	5440	M.81-1.00 S1.8-2.3	79	78	100	100	126	G

- (1) M = Main winding = yellow to black;  
S = Start winding - yellow to red
- (2) Y = Yellow lead - line amps;  
B = Black lead - main winding amps  
R = Red lead - start or auxiliary winding amps

**Table 13 Single-Phase Motor Specifications (60 Hz) 700 Series**

TYPE	MOTOR MODEL PREFIX	RATING					FULL LOAD		MAXIMUM LOAD		WINDING (1) RES. IN OHMS	EFFICIENCY %		POWER FACTOR %		LOCKED ROTOR AMPS	KVA CODE
		HP	KW	VOLTS	HZ	S.F.	(2) AMPS	WATTS	(2) AMPS	WATTS	M=MAIN RES. S=START RES.	S.F.	F.L.	S.F.	F.L.		
4" 3-WIRE	224702	3	2.2	230	60	1.15	Y13.3 B10.6 R6.1	2980	Y17.0 B13.9 R5.9	3400	M1.1-1.4 S3.0-3.7	76	75	97	97	77.9	G
	224703	5	3.7	230	60	1.15	Y21.3 B14.5 R10.5	4860	Y27.5 B21.3 R10.1	55880	M0.78-0.95 S1.8-2.2	77	77	100	100	107	E

Performance is typical, not guaranteed, at specified voltages and specified capacitor values. Performance at voltage ratings not shown is similar, except amps vary inversely with voltage.

# Single-Phase Motors

## MOTOR APPLICATION

**Table 14 Single-Phase Motor Fuse Sizing**

TYPE	MOTOR MODEL PREFIX	RATING			CIRCUIT BREAKERS OR FUSE AMPS			CIRCUIT BREAKERS OR FUSE AMPS		
					(MAXIMUM PER NEC)			(TYPICAL SUBMERSIBLE)		
		HP	KW	VOLTS	STANDARD FUSE	DUAL ELEMENT TIME DELAY FUSE	CIRCUIT BREAKER	STANDARD FUSE	DUAL ELEMENT TIME DELAY FUSE	CIRCUIT BREAKER
4" 2-WIRE	244504	1/2	0.37	115	35	20	30	30	15	30
	244505	1/2	0.37	230	20	10	15	15	8	15
	244507	3/4	0.55	230	25	15	20	20	10	20
	244508	1	0.75	230	30	20	25	25	11	25
	244309	1.5	1.1	230	35	20	30	35	15	30
4" 3-WIRE	214504	1/2	0.37	115	35	20	30	30	15	30
	214505	1/2	0.37	230	20	10	15	15	8	15
	214507	3/4	0.55	230	25	15	20	20	10	20
	214508	1	0.75	230	30	20	25	25	11	25
4" 3-WIRE W/CRC CB	214505	1/2	0.37	230	20	10	15	15	8	15
	214507	3/4	0.55	230	25	15	20	20	10	20
	214508	1	0.75	230	30	20	25	25	11	25
4" 3-WIRE	214508 W/ 1-1.5 CB	1	0.75	230	30	20	25	25	11	25
	224300	1.5	1.1	230	35	20	30	30	15	30
	224301	2	1.5	230	30	20	25	30	15	30
	224302	3	2.2	230	45	30	40	45	20	40
	224303	5	3.7	230	80	45	60	70	30	60
6"	226110	5	3.7	230	80	45	60	70	30	60
	226111	7.5	5.5	230	125	70	100	110	50	100
	226112	10	7.5	230	150	80	125	150	60	125
	226113	15	11	230	200	125	175	200	90	175

# Single-Phase Motors

## MOTOR APPLICATION

### Auxiliary Running Capacitors

Added capacitors must be connected across “Red” and “Black” control box terminals, in parallel with any existing running capacitors. The additional capacitor(s) should be mounted in an auxiliary box. The values of additional running capacitors most likely to reduce noise are given below. The tabulation gives the **max.** S.F. amps normally in each lead with the added capacitor.

**Although motor amps decrease when auxiliary run capacitance is added, the load on the motor does not. If a motor is overloaded with normal capacitance, it will still be overloaded with auxiliary run capacitance, even though motor amps may be within nameplate values.**

**Table 15 Auxiliary Capacitor Sizing**

MOTOR RATING		NORMAL RUNNING CAPACITOR(S)	AUXILIARY RUNNING CAPACITORS FOR NOISE REDUCTION			MAXIMUM AMPS WITH RUN CAP		
HP	VOLTS	MFD	MFD	MIN. VOLTS	FRANKLIN PART	YELLOW	BLACK	RED
1/2	115	0	60(1)	370	TWO 155327101	8.4	7.0	4.0
1/2	230	0	15(1)	370	ONE 155328101	4.2	3.5	2.0
3/4		0	20(1)	370	ONE 155328103	5.8	5.0	2.5
1		0	25(1)	370	ONE EA. 155328101 155328102	7.1	5.6	3.4
1.5		10	20	370	ONE 155328103	9.3	7.5	4.4
2		20	10	370	ONE 155328102	11.2	9.2	3.8
3		45	NONE	370		17.0	12.6	6.0
5		80	NONE	370		27.5	19.1	10.8
7.5		45	45	370	ONE EA. 155327101 155328101	37.0	32.0	11.3
10		70	30	370	ONE 155327101	49.0	42.0	13.0
15		135	NONE			75.0	62.5	16.9

(1) Do not add running capacitors to 1/3 through 1 hp control boxes, which use solid state switches or QD relays. Adding capacitors will cause switch failure. If the control box is converted to use a voltage relay, the specified running capacitance can be added.

### Buck-Boost Transformers

When the available power supply voltage is not within the proper range, a buck-boost transformer is often used to adjust voltage to match the motor. The most common usage on submersible motors is boosting a 208 Volt supply to use a standard 230 Volt single-phase submersible motor and control. While tables to give a wide range of

voltage boost or buck are published by transformer manufacturers, the following table shows Franklin’s recommendations. The table, based on boosting the voltage 10%, shows the minimum rated transformer kVA needed and the common standard transformer kVA.

**Table 15A Buck-Boost Transformer Sizing**

MOTOR HP	1/3	1/2	3/4	1	1.5	2	3	5	7.5	10	15
LOAD KVA	1.02	1.36	1.84	2.21	2.65	3.04	3.91	6.33	9.66	11.70	16.60
MINIMUM XFMR KVA	0.11	0.14	0.19	0.22	0.27	0.31	0.40	0.64	0.97	1.20	1.70
STANDARD XFMR KVA	0.25	0.25	0.25	0.25	0.50	0.50	0.50	0.75	1.00	1.50	2.00

Buck-Boost transformers are power transformers, not control transformers. They may also be used to lower voltage when the available power supply voltage is too high.

# Three-Phase Motors

## MOTOR APPLICATION

60 °C

Table 16 Three-Phase 60 °C Cable, 60 Hz, 3-Lead Motor (Service Entrance to Motor) Maximum Length in Feet

MOTOR RATING			60 °C INSULATION - AWG COPPER WIRE SIZE												MCM COPPER WIRE SIZE						
VOLTS	HP	KW	14	12	10	8	6	4	3	2	1	0	00	000	0000	250	300	350	400	500	
200 V 60 Hz Three-Phase 3 - Lead	1/2	0.37	710	1140	1800	2840	4420														
	3/4	0.55	510	810	1280	2030	3160														
	1	0.75	430	690	1080	1710	2670	4140	5140												
	1.5	1.1	310	500	790	1260	1960	3050	3780												
	2	1.5	240	390	610	970	1520	2360	2940	3610	4430	5420									
	3	2.2	180	290	470	740	1160	1810	2250	2760	3390	4130									
	5	3.7	110	170	280	440	690	1080	1350	1660	2040	2490	3050	3670	4440	5030					
	7.5	5.5	0	0	200	310	490	770	960	1180	1450	1770	2170	2600	3150	3560					
	10	7.5	0	0	0	<b>230</b>	370	570	720	880	1090	1330	1640	1970	2390	2720	3100	3480	3800	4420	
	15	11	0	0	0	<b>160</b>	<b>250</b>	390	490	600	740	910	1110	1340	1630	1850	2100	2350	2570	2980	
	20	15	0	0	0	0	<b>190</b>	<b>300</b>	380	460	570	700	860	1050	1270	1440	1650	1850	2020	2360	
	25	18.5	0	0	0	0	0	<b>240</b>	<b>300</b>	<b>370</b>	460	570	700	840	1030	1170	1330	1500	1640	1900	
30	22	0	0	0	0	0	0	<b>250</b>	<b>310</b>	<b>380</b>	470	580	700	850	970	1110	1250	1360	1590		
230 V 60 Hz Three-Phase 3 - Lead	1/2	0.37	930	1490	2350	3700	5760	8910													
	3/4	0.55	670	1080	1700	2580	4190	6490	8060	9860											
	1	0.75	560	910	1430	2260	3520	5460	6780	8290											
	1.5	1.1	420	670	1060	1670	2610	4050	5030	6160	7530	9170									
	2	1.5	320	510	810	1280	2010	3130	3890	4770	5860	7170	8780								
	3	2.2	240	390	620	990	1540	2400	2980	3660	4480	5470	6690	8020	9680						
	5	3.7	140	230	370	590	920	1430	1790	2190	2690	3290	4030	4850	5870	6650	7560	8460	9220		
	7.5	5.5	0	<b>160</b>	260	420	650	1020	1270	1560	1920	2340	2870	3440	4160	4710	5340	5970	6500	7510	
	10	7.5	0	0	<b>190</b>	310	490	760	950	1170	1440	1760	2160	2610	3160	3590	4100	4600	5020	5840	
	15	11	0	0	0	<b>210</b>	330	520	650	800	980	1200	1470	1780	2150	2440	2780	3110	3400	3940	
	20	15	0	0	0	0	<b>250</b>	400	500	610	760	930	1140	1380	1680	1910	2180	2450	2680	3120	
	25	18.5	0	0	0	0	0	<b>320</b>	400	500	610	750	920	1120	1360	1540	1760	1980	2160	2520	
30	22	0	0	0	0	0	<b>260</b>	<b>330</b>	<b>410</b>	510	620	760	930	1130	1280	1470	1650	1800	2110		
380 V 60 Hz Three-Phase 3 - Lead	1/2	0.37	2690	4290	6730																
	3/4	0.55	2000	3190	5010	7860															
	1	0.75	1620	2580	4060	6390	9980														
	1.5	1.1	1230	1970	3100	4890	7630														
	2	1.5	870	1390	2180	3450	5400	8380													
	3	2.2	680	1090	1710	2690	4200	6500	8020	9830											
	5	3.7	400	640	1010	1590	2490	3870	4780	5870	7230	8830									
	7.5	5.5	270	440	690	1090	1710	2640	3260	4000	4930	6010	7290	8780							
	10	7.5	<b>200</b>	<b>320</b>	510	800	1250	1930	2380	2910	3570	4330	5230	6260	7390	8280	9340				
	15	11	0	0	<b>370</b>	590	920	1430	1770	2170	2690	3290	4000	4840	5770	6520	7430	8250	8990		
	20	15	0	0	0	<b>440</b>	700	1090	1350	1670	2060	2530	3090	3760	4500	5110	5840	6510	7120	8190	
	25	18.5	0	0	0	<b>360</b>	570	880	1100	1350	1670	2050	2510	3040	3640	4130	4720	5250	5740	6590	
	30	22	0	0	0	0	<b>470</b>	730	910	1120	1380	1700	2080	2520	3020	3430	3920	4360	4770	5490	
	40	30	0	0	0	0	0	<b>530</b>	660	820	1010	1240	1520	1840	2200	2500	2850	3170	3470	3990	
	50	37	0	0	0	0	0	0	<b>540</b>	<b>660</b>	820	1000	1220	1480	1770	2010	2290	2550	2780	3190	
	60	45	0	0	0	0	0	0	0	<b>560</b>	<b>690</b>	850	1030	1250	1500	1700	1940	2150	2350	2700	
	75	55	0	0	0	0	0	0	0	0	<b>570</b>	<b>700</b>	<b>860</b>	1050	1270	1440	1660	1850	2030	2350	
	100	75	0	0	0	0	0	0	0	0	0	<b>510</b>	<b>630</b>	<b>760</b>	910	1030	1180	1310	1430	1650	
125	93	0	0	0	0	0	0	0	0	0	0	0	<b>620</b>	<b>740</b>	<b>840</b>	<b>950</b>	1060	1160	1330		
150	110	0	0	0	0	0	0	0	0	0	0	0	0	<b>620</b>	<b>700</b>	<b>790</b>	<b>880</b>	<b>960</b>	1090		
175	130	0	0	0	0	0	0	0	0	0	0	0	0	0	<b>650</b>	<b>750</b>	<b>840</b>	<b>920</b>	1070		
200	150	0	0	0	0	0	0	0	0	0	0	0	0	0	0	<b>630</b>	<b>700</b>	<b>760</b>	<b>880</b>		

Lengths in **BOLD** only meet the US National Electrical Code ampacity requirements for individual conductors in free air or water. Lengths NOT in bold meet NEC ampacity requirements for either individual conductors or jacketed cable. See page 11 for additional details.

**NOTE:** Wire tables are based on copper wire. If aluminum wire is used, it must be two sizes larger than copper wire and oxidation inhibitors must be used on connections.

Continued on next page

# Three-Phase Motors

## MOTOR APPLICATION

60 °C

Table 16 Three-Phase 60 °C Cable, 60 Hz, 3-Lead Motor (Service Entrance to Motor) Maximum Length in Feet (Continued)

MOTOR RATING			60 °C INSULATION - AWG COPPER WIRE SIZE													MCM COPPER WIRE SIZE					
VOLTS	HP	KW	14	12	10	8	6	4	3	2	1	0	00	000	0000	250	300	350	400	500	
460 V 60 Hz Three- Phase 3 - Lead	1/2	0.37	3770	6020	9460																
	3/4	0.55	2730	4350	6850																
	1	0.75	2300	3670	5770	9070															
	1.5	1.1	1700	2710	4270	6730															
	2	1.5	1300	2070	3270	5150	8050														
	3	2.2	1000	1600	2520	3970	6200														
	5	3.7	590	950	1500	2360	3700	5750													
	7.5	5.5	420	680	1070	1690	2640	4100	5100	6260	7680										
	10	7.5	310	500	790	1250	1960	3050	3800	4680	5750	7050									
	15	11	0	<b>340</b>	540	850	1340	2090	2600	3200	3930	4810	5900	7110							
	20	15	0	0	<b>410</b>	650	1030	1610	2000	2470	3040	3730	4580	5530							
	25	18.5	0	0	0	<b>530</b>	830	1300	1620	1990	2450	3010	3700	4470	5430						
	30	22	0	0	0	<b>430</b>	680	1070	1330	1640	2030	2490	3060	3700	4500	5130	5860				
	40	30	0	0	0	0	<b>500</b>	790	980	1210	1490	1830	2250	2710	3290	3730	4250				
	50	37	0	0	0	0	0	<b>640</b>	800	980	1210	1480	1810	2190	2650	3010	3420	3830	4180	4850	
	60	45	0	0	0	0	0	0	<b>540</b>	<b>670</b>	<b>830</b>	1020	1250	1540	1850	2240	2540	2890	3240	3540	4100
	75	55	0	0	0	0	0	0	0	0	<b>680</b>	<b>840</b>	1030	1260	1520	1850	2100	2400	2700	2950	3440
	100	75	0	0	0	0	0	0	0	0	0	<b>620</b>	<b>760</b>	<b>940</b>	1130	1380	1560	1790	2010	2190	2550
	125	93	0	0	0	0	0	0	0	0	0	0	0	<b>740</b>	<b>890</b>	<b>1000</b>	1220	1390	1560	1700	1960
	150	110	0	0	0	0	0	0	0	0	0	0	0	0	<b>760</b>	<b>920</b>	<b>1050</b>	<b>1190</b>	1340	1460	1690
175	130	0	0	0	0	0	0	0	0	0	0	0	0	0	<b>810</b>	<b>930</b>	<b>1060</b>	<b>1190</b>	1300	1510	
200	150	0	0	0	0	0	0	0	0	0	0	0	0	0	0	<b>810</b>	<b>920</b>	<b>1030</b>	<b>1130</b>	1310	
575 V 60 Hz Three- Phase 3 - Lead	1/2	0.37	5900	9410																	
	3/4	0.55	4270	6810																	
	1	0.75	3630	5800	9120																
	1.5	1.1	2620	4180	6580																
	2	1.5	2030	3250	5110	8060															
	3	2.2	1580	2530	3980	6270															
	5	3.7	920	1480	2330	3680	5750														
	7.5	5.5	660	1060	1680	2650	4150														
	10	7.5	490	780	1240	1950	3060	4770	5940												
	15	11	<b>330</b>	530	850	1340	2090	3260	4060												
	20	15	0	<b>410</b>	650	1030	1610	2520	3140	3860	4760	5830									
	25	18.5	0	0	<b>520</b>	830	1300	2030	2530	3110	3840	4710									
	30	22	0	0	<b>430</b>	680	1070	1670	2080	2560	3160	3880	4770	5780	7030	8000					
	40	30	0	0	0	<b>500</b>	790	1240	1540	1900	2330	2860	3510	4230	5140	5830					
	50	37	0	0	0	0	<b>640</b>	1000	1250	1540	1890	2310	2840	3420	4140	4700	5340	5990	6530	7580	
	60	45	0	0	0	0	0	<b>850</b>	1060	1300	1600	1960	2400	2890	3500	3970	4520	5070	5530	6410	
	75	55	0	0	0	0	0	0	<b>690</b>	<b>860</b>	<b>1060</b>	1310	1600	1970	2380	2890	3290	3750	5220	4610	5370
	100	75	0	0	0	0	0	0	0	0	<b>790</b>	<b>970</b>	<b>1190</b>	1460	1770	2150	2440	2790	3140	3430	3990
	125	93	0	0	0	0	0	0	0	0	0	<b>770</b>	<b>950</b>	<b>1160</b>	1400	1690	1920	2180	2440	2650	3070
	150	110	0	0	0	0	0	0	0	0	0	0	<b>800</b>	<b>990</b>	<b>1190</b>	1440	1630	1860	2080	2270	2640
175	130	0	0	0	0	0	0	0	0	0	0	0	<b>870</b>	<b>1050</b>	<b>1270</b>	<b>1450</b>	1650	1860	2030	2360	
200	150	0	0	0	0	0	0	0	0	0	0	0	0	<b>920</b>	<b>1110</b>	<b>1260</b>	<b>1440</b>	1620	1760	2050	

Lengths in **BOLD** only meet the US National Electrical Code ampacity requirements for individual conductors in free air or water. Lengths NOT in bold meet NEC ampacity requirements for either individual conductors or jacketed cable. See page 11 for additional details.

**NOTE:** Wire tables are based on copper wire. If aluminum wire is used, it must be two sizes larger than copper wire and oxidation inhibitors must be used on connections.

# Three-Phase Motors

## MOTOR APPLICATION

**60 °C**

Table 17 Three-Phase 60 °C Cable, 60 HZ, 6-Lead Motors (Service Entrance to Motor) Maximum Length in Feet

MOTOR RATING			60 °C INSULATION - AWG COPPER WIRE SIZE													MCM COPPER WIRE SIZE					
VOLTS	HP	KW	14	12	10	8	6	4	3	2	1	0	00	000	0000	250	300	350	400	500	
200 V 60 Hz Three-Phase 6 - Lead Y-D	5	3.7	160	250	420	660	1030	1620	2020	2490	3060	3730	4570	5500	6660	7540					
	7.5	5.5	110	180	300	460	730	1150	1440	1770	2170	2650	3250	3900	4720	5340					
	10	7.5	<b>80</b>	130	210	340	550	850	1080	1320	1630	1990	2460	2950	3580	4080	4650	5220	5700	6630	
	15	11	0	0	<b>140</b>	240	370	580	730	900	1110	1360	1660	2010	2440	2770	3150	3520	3850	4470	
	20	15	0	0	0	<b>170</b>	280	450	570	690	850	1050	1290	1570	1900	2160	2470	2770	3030	3540	
	25	18.5	0	0	0	<b>140</b>	<b>220</b>	360	450	550	690	850	1050	1260	1540	1750	1990	2250	2460	2850	
230 V 60 Hz Three-Phase 6 - Lead Y-D	5	3.7	210	340	550	880	1380	2140	2680	3280	4030	4930	6040	7270	8800	9970					
	7.5	5.5	150	240	390	630	970	1530	1900	2340	2880	3510	4300	5160	6240	7060	8010	8950	9750		
	10	7.5	<b>110</b>	180	280	460	730	1140	1420	1750	2160	2640	3240	3910	4740	5380	6150	6900	7530	8760	
	15	11	0	0	<b>190</b>	310	490	780	970	1200	1470	1800	2200	2670	3220	3660	4170	4660	5100	5910	
	20	15	0	0	<b>140</b>	230	370	600	750	910	1140	1390	1710	2070	2520	2860	3270	3670	4020	4680	
	25	18.5	0	0	0	<b>190</b>	300	480	600	750	910	1120	1380	1680	2040	2310	2640	2970	3240	3780	
380 V 60 Hz Three-Phase 6 - Lead Y-D	5	3.7	600	960	1510	2380	3730	5800	7170	8800											
	7.5	5.5	400	660	1030	1630	2560	3960	4890	6000	7390	9010									
	10	7.5	300	480	760	1200	1870	2890	3570	4360	5350	6490	7840	9390							
	15	11	210	340	550	880	1380	2140	2650	3250	4030	4930	6000	7260	8650	9780					
	20	15	<b>160</b>	260	410	660	1050	1630	2020	2500	3090	3790	4630	5640	6750	7660	4260	9760			
	25	18.5	0	<b>210</b>	330	540	850	1320	1650	2020	2500	3070	3760	4560	5460	6190	7080	7870	8610	9880	
	30	22	0	0	<b>270</b>	430	700	1090	1360	1680	2070	2550	3120	3780	4530	5140	5880	6540	7150	8230	
	40	30	0	0	0	<b>320</b>	510	790	990	1230	1510	1860	2280	2760	3300	3750	4270	4750	5200	5980	
	50	37	0	0	0	<b>250</b>	<b>400</b>	630	810	990	1230	1500	1830	2220	2650	3010	3430	3820	4170	4780	
	60	45	0	0	0	0	<b>340</b>	540	660	840	1030	1270	1540	1870	2250	2550	2910	3220	3520	4050	
	75	55	0	0	0	0	0	<b>450</b>	550	690	855	1050	1290	1570	1900	2160	2490	2770	3040	3520	
	100	75	0	0	0	0	0	0	<b>420</b>	<b>520</b>	640	760	940	1140	1360	1540	1770	1960	2140	2470	
	125	93	0	0	0	0	0	0	0	<b>400</b>	<b>490</b>	<b>600</b>	730	930	1110	1260	1420	1590	1740	1990	
	150	110	0	0	0	0	0	0	0	0	<b>420</b>	<b>510</b>	<b>620</b>	750	930	1050	1180	1320	1440	1630	
175	130	0	0	0	0	0	0	0	0	<b>360</b>	<b>440</b>	<b>540</b>	660	780	970	1120	1260	1380	1600		
200	150	0	0	0	0	0	0	0	0	0	0	<b>480</b>	<b>580</b>	<b>690</b>	790	940	1050	1140	1320		
460 V 60 Hz Three-Phase 6 - Lead Y-D	5	3.7	880	1420	2250	3540	5550	8620													
	7.5	5.5	630	1020	1600	2530	3960	6150	7650	9390											
	10	7.5	460	750	1180	1870	2940	4570	5700	7020	8620										
	15	11	310	510	810	1270	2010	3130	3900	4800	5890	7210	8850								
	20	15	<b>230</b>	380	610	970	1540	2410	3000	3700	4560	5590	6870	8290							
	25	18.5	<b>190</b>	310	490	790	1240	1950	2430	2980	3670	4510	5550	6700	8140						
	30	22	0	<b>250</b>	410	640	1020	1600	1990	2460	3040	3730	4590	5550	6750	7690	8790				
	40	30	0	0	<b>300</b>	480	750	1180	1470	1810	2230	2740	3370	4060	4930	5590	6370				
	50	37	0	0	0	<b>370</b>	590	960	1200	1470	1810	2220	2710	3280	3970	4510	5130	5740	6270	7270	
	60	45	0	0	0	<b>320</b>	<b>500</b>	810	1000	1240	1530	1870	2310	2770	3360	3810	4330	4860	5310	6150	
	75	55	0	0	0	0	<b>420</b>	660	810	1020	1260	1540	1890	2280	2770	3150	3600	4050	4420	5160	
	100	75	0	0	0	0	0	<b>500</b>	<b>610</b>	760	930	1140	1410	1690	2070	2340	2680	3010	3280	3820	
	125	93	0	0	0	0	0	0	<b>470</b>	<b>590</b>	<b>730</b>	880	1110	1350	1500	1830	2080	2340	2550	2940	
	150	110	0	0	0	0	0	0	0	<b>510</b>	<b>630</b>	<b>770</b>	950	1140	1380	1570	1790	2000	2180	2530	
175	130	0	0	0	0	0	0	0	0	<b>550</b>	<b>680</b>	<b>830</b>	1000	1220	1390	1580	1780	1950	2270		
200	150	0	0	0	0	0	0	0	0	0	<b>590</b>	<b>730</b>	<b>880</b>	1070	1210	1380	1550	1690	1970		
575 V 60 Hz Three-Phase 6 - Lead Y-D	5	3.7	1380	2220	3490	5520	8620														
	7.5	5.5	990	1590	2520	3970	6220														
	10	7.5	730	1170	1860	2920	4590	7150	8910												
	15	11	490	790	1270	2010	3130	4890	6090												
	20	15	370	610	970	1540	2410	3780	4710	5790	7140	8740									
	25	18.5	<b>300</b>	490	780	1240	1950	3040	3790	4660	5760	7060									
	30	22	<b>240</b>	400	645	1020	1600	2500	3120	3840	4740	5820	7150	8670							
	40	30	0	<b>300</b>	480	750	1180	1860	2310	2850	3490	4290	5260	6340	7710	8740					
	50	37	0	0	<b>380</b>	590	960	1500	1870	2310	2830	3460	4260	5130	6210	7050	8010	8980	9790		
	60	45	0	0	0	<b>500</b>	<b>790</b>	1270	1590	1950	2400	2940	3600	4330	5250	5950	6780	7600	8290	9610	
	75	55	0	0	0	<b>420</b>	<b>660</b>	1030	1290	1590	1960	2400	2950	3570	4330	4930	5620	6330	6910	8050	
	100	75	0	0	0	0	<b>400</b>	<b>780</b>	960	1180	1450	1780	2190	2650	3220	3660	4180	4710	5140	5980	
	125	93	0	0	0	0	0	<b>600</b>	<b>740</b>	920	1150	1420	1740	2100	2530	2880	3270	3660	3970	4600	
	150	110	0	0	0	0	0	0	<b>650</b>	<b>800</b>	<b>990</b>	1210	1480	1780	2160	2450	2790	3120	3410	3950	
175	130	0	0	0	0	0	0	0	<b>700</b>	<b>860</b>	1060	1300	1570	1910	2170	2480	2780	3040	3540		
200	150	0	0	0	0	0	0	0	0	<b>760</b>	<b>930</b>	1140	1370	1670	1890	2160	2420	2640	3070		

Lengths in **BOLD** only meet the US National Electrical Code ampacity requirements for individual conductors in free air or water. Lengths NOT in bold meet NEC ampacity requirements for either individual conductors or jacketed cable. See page 11 for additional details.

**NOTE:** Wire tables are based on copper wire. If aluminum wire is used, it must be two sizes larger than copper wire and oxidation inhibitors must be used on connections.

# Three-Phase Motors

## MOTOR APPLICATION

75 °C

Table 18 Three-Phase 75 °C Cable, 60 Hz, 3-Lead Motor (Service Entrance to Motor) Maximum Length in Feet

MOTOR RATING			75 °C INSULATION - AWG COPPER WIRE SIZE												MCM COPPER WIRE SIZE						
VOLTS	HP	KW	14	12	10	8	6	4	3	2	1	0	00	000	0000	250	300	350	400	500	
200 V 60 Hz Three-Phase 3-Lead	1/2	0.37	710	1140	1800	2840	4420														
	3/4	0.55	510	810	1280	2030	3160														
	1	0.75	430	690	1080	1710	2670	4140	5140												
	1.5	1.1	310	500	790	1260	1960	3050	3780												
	2	1.5	240	390	610	970	1520	2360	2940	3610	4430	5420									
	3	2.2	180	290	470	740	1160	1810	2250	2760	3390	4130									
	5	3.7	<b>110</b>	170	280	440	690	1080	1350	1660	2040	2490	3050	3670	4440	5030					
	7.5	5.5	0	0	200	310	490	770	960	1180	1450	1770	2170	2600	3150	3560					
	10	7.5	0	0	<b>150</b>	230	370	570	720	880	1090	1330	1640	1970	2390	2720	3100	3480	3800	4420	
	15	11	0	0	0	<b>160</b>	250	390	490	600	740	910	1110	1340	1630	1850	2100	2350	2570	2980	
	20	15	0	0	0	0	<b>190</b>	300	380	460	570	700	860	1050	1270	1440	1650	1850	2020	2360	
	25	18.5	0	0	0	0	0	<b>240</b>	300	370	460	570	700	840	1030	1170	1330	1500	1640	1900	
30	22	0	0	0	0	0	<b>200</b>	<b>250</b>	310	380	470	580	700	850	970	1110	1250	1360	1590		
230 V 60 Hz Three-Phase 3-Lead	1/2	0.37	930	1490	2350	3700	5760	8910													
	3/4	0.55	670	1080	1700	2580	4190	6490	8060	9860											
	1	0.75	560	910	1430	2260	3520	5460	6780	8290											
	1.5	1.1	420	670	1060	1670	2610	4050	5030	6160	7530	9170									
	2	1.5	320	510	810	1280	2010	3130	3890	4770	5860	7170	8780								
	3	2.2	240	390	620	990	1540	2400	2980	3660	4480	5470	6690	8020	9680						
	5	3.7	<b>140</b>	230	370	590	920	1430	1790	2190	2690	3290	4030	4850	5870	6650	7560	8460	9220		
	7.5	5.5	0	<b>160</b>	260	420	650	1020	1270	1560	1920	2340	2870	3440	4160	4710	5340	5970	6500	7510	
	10	7.5	0	0	<b>190</b>	310	490	760	950	1170	1440	1760	2160	2610	3160	3590	4100	4600	5020	5840	
	15	11	0	0	0	<b>210</b>	330	520	650	800	980	1200	1470	1780	2150	2440	2780	3110	3400	3940	
	20	15	0	0	0	<b>160</b>	<b>250</b>	400	500	610	760	930	1140	1380	1680	1910	2180	2450	2680	3120	
	25	18.5	0	0	0	0	<b>200</b>	320	400	500	610	750	920	1120	1360	1540	1760	1980	2160	2520	
30	22	0	0	0	0	0	<b>260</b>	330	410	510	620	760	930	1130	1280	1470	1650	1800	2110		
380 V 60 Hz Three-Phase 3-Lead	1/2	0.37	2690	4290	6730																
	3/4	0.55	2000	3190	5010	7860															
	1	0.75	1620	2580	4060	6390	9980														
	1.5	1.1	1230	1970	3100	4890	7630														
	2	1.5	870	1390	2180	3450	5400	8380													
	3	2.2	680	1090	1710	2690	4200	6500	8020	9830											
	5	3.7	400	640	1010	1590	2490	3870	4780	5870	7230	8830									
	7.5	5.5	270	440	690	1090	1710	2640	3260	4000	4930	6010	7290	8780							
	10	7.5	<b>200</b>	320	510	800	1250	1930	2380	2910	3570	4330	5230	6260	7390	8280	9340				
	15	11	0	0	370	590	920	1430	1770	2170	2690	3290	4000	4840	5770	6520	7430	8250	8990		
	20	15	0	0	<b>280</b>	440	700	1090	1350	1670	2060	2530	3090	3760	4500	5110	2840	6510	7120	8190	
	25	18.5	0	0	0	<b>360</b>	570	880	1100	1350	1670	2050	2510	3040	3640	4130	4720	5250	5740	6590	
	30	22	0	0	0	<b>290</b>	470	730	910	1120	1380	1700	2080	2520	3020	3430	3920	4360	4770	5490	
	40	30	0	0	0	0	0	<b>530</b>	660	820	1010	1240	1520	1840	2200	2500	2850	3170	3470	3990	
	50	37	0	0	0	0	0	<b>440</b>	<b>540</b>	660	820	1000	1220	1480	1770	2010	2290	2550	2780	3190	
	60	45	0	0	0	0	0	<b>370</b>	<b>460</b>	<b>560</b>	690	850	1030	1250	1500	1700	1940	2150	2350	2700	
	75	55	0	0	0	0	0	0	0	<b>460</b>	<b>570</b>	700	860	1050	1270	1440	1660	1850	2030	2350	
	100	75	0	0	0	0	0	0	0	0	<b>420</b>	<b>510</b>	<b>630</b>	760	910	1030	1180	1310	1430	1650	
125	93	0	0	0	0	0	0	0	0	0	0	<b>510</b>	<b>620</b>	<b>740</b>	840	950	1060	1160	1330		
150	110	0	0	0	0	0	0	0	0	0	0	0	<b>520</b>	<b>620</b>	<b>700</b>	<b>790</b>	880	960	1090		
175	130	0	0	0	0	0	0	0	0	0	0	0	0	<b>560</b>	<b>650</b>	<b>750</b>	<b>840</b>	920	1070		
200	150	0	0	0	0	0	0	0	0	0	0	0	0	0	<b>550</b>	<b>630</b>	<b>700</b>	<b>760</b>	880		

Lengths in **BOLD** only meet the US National Electrical Code ampacity requirements for individual conductors in free air or water. Lengths NOT in bold meet NEC ampacity requirements for either individual conductors or jacketed cable. See page 11 for additional details.

**NOTE:** Wire tables are based on copper wire. If aluminum wire is used, it must be two sizes larger than copper wire and oxidation inhibitors must be used on connections.

Continued on next page

# Three-Phase Motors

## MOTOR APPLICATION

75 °C

Table 18 Three-Phase 75 °C Cable, 60 Hz, 3-Lead Motor (Service Entrance to Motor) Maximum Length in Feet (Continued)

MOTOR RATING			75 °C INSULATION - AWG COPPER WIRE SIZE											MCM COPPER WIRE SIZE							
VOLTS	HP	KW	14	12	10	8	6	4	3	2	1	0	00	000	0000	250	300	350	400	500	
460 V 60 Hz Three- Phase 3 - Lead	1/2	0.37	3770	6020	9460																
	3/4	0.55	2730	4350	6850																
	1	0.75	2300	3670	5770	9070															
	1.5	1.1	1700	2710	4270	6730															
	2	1.5	1300	2070	3270	5150	8050														
	3	2.2	1000	1600	2520	3970	6200														
	5	3.7	590	950	1500	2360	3700	5750													
	7.5	5.5	420	680	1070	1690	2640	4100	5100	6260	7680										
	10	7.5	310	500	790	1250	1960	3050	3800	4680	5750	7050									
	15	11	0	<b>340</b>	540	850	1340	2090	2600	3200	3930	4810	5900	7110							
	20	15	0	0	410	650	1030	1610	2000	2470	3040	3730	4580	5530							
	25	18.5	0	0	<b>330</b>	530	830	1300	1620	1990	2450	3010	3700	4470	5430						
	30	22	0	0	<b>270</b>	430	680	1070	1330	1640	2030	2490	3060	3700	4500	5130	5860				
	40	30	0	0	0	<b>320</b>	<b>500</b>	790	980	1210	1490	1830	2250	2710	3290	3730	4250				
	50	37	0	0	0	0	<b>410</b>	640	800	980	1210	1480	1810	2190	2650	3010	3420	3830	4180	4850	
	60	45	0	0	0	0	0	<b>540</b>	<b>670</b>	830	1020	1250	1540	1850	2240	2540	2890	3240	3540	4100	
	75	55	0	0	0	0	0	<b>440</b>	<b>550</b>	<b>680</b>	840	1030	1260	1520	1850	2100	2400	2700	2950	3440	
	100	75	0	0	0	0	0	0	0	<b>500</b>	<b>620</b>	<b>760</b>	940	1130	1380	1560	1790	2010	2190	2550	
	125	93	0	0	0	0	0	0	0	0	0	<b>600</b>	<b>740</b>	<b>890</b>	1000	1220	1390	1560	1700	1960	
	150	110	0	0	0	0	0	0	0	0	0	0	<b>630</b>	<b>760</b>	<b>920</b>	1050	1190	1340	1460	1690	
175	130	0	0	0	0	0	0	0	0	0	0	0	<b>670</b>	<b>810</b>	<b>930</b>	1060	1190	1300	1510		
200	150	0	0	0	0	0	0	0	0	0	0	0	<b>590</b>	<b>710</b>	<b>810</b>	<b>920</b>	1030	1130	1310		
575 V 60 Hz Three- Phase 3 - Lead	1/2	0.37	5900	9410																	
	3/4	0.55	4270	6810																	
	1	0.75	3630	5800	9120																
	1.5	1.1	2620	4180	6580																
	2	1.5	2030	3250	5110	8060															
	3	2.2	1580	2530	3980	6270															
	5	3.7	920	1480	2330	3680	5750														
	7.5	5.5	660	1060	1680	2650	4150														
	10	7.5	490	780	1240	1950	3060	4770	5940												
	15	11	<b>330</b>	530	850	1340	2090	3260	4060												
	20	15	0	<b>410</b>	650	1030	1610	2520	3140	3860	4760	5830									
	25	18.5	0	0	520	830	1300	2030	2530	3110	3840	4710									
	30	22	0	0	<b>430</b>	680	1070	1670	2080	2560	3160	3880	4770	5780	7030	8000					
	40	30	0	0	0	<b>500</b>	790	1240	1540	1900	2330	2860	3510	4230	5140	5830					
	50	37	0	0	0	<b>410</b>	<b>640</b>	1000	1250	1540	1890	2310	2840	3420	4140	4700	5340	5990	6530	7580	
	60	45	0	0	0	0	<b>540</b>	850	1060	1300	1600	1960	2400	2890	3500	3970	4520	5070	5530	6410	
	75	55	0	0	0	0	0	<b>690</b>	860	1060	1310	1600	1970	2380	2890	3290	3750	5220	4610	5370	
	100	75	0	0	0	0	0	0	<b>640</b>	<b>790</b>	970	1190	1460	1770	2150	2440	2790	3140	3430	3990	
	125	93	0	0	0	0	0	0	0	<b>630</b>	<b>770</b>	<b>950</b>	1160	1400	1690	1920	2180	2440	2650	3070	
	150	110	0	0	0	0	0	0	0	0	0	<b>660</b>	<b>800</b>	<b>990</b>	1190	1440	1630	1860	2080	2270	2640
175	130	0	0	0	0	0	0	0	0	0	<b>700</b>	<b>870</b>	<b>1050</b>	1270	1450	1650	1860	2030	2360		
200	150	0	0	0	0	0	0	0	0	0	<b>760</b>	<b>920</b>	<b>1110</b>	1260	1440	1620	1760	2050			

Lengths in **BOLD** only meet the US National Electrical Code ampacity requirements for individual conductors in free air or water. Lengths NOT in bold meet NEC ampacity requirements for either individual conductors or jacketed cable. See page 11 for additional details.

**NOTE:** Wire tables are based on copper wire. If aluminum wire is used, it must be two sizes larger than copper wire and oxidation inhibitors must be used on connections.





# Three-Phase Motors

## MOTOR APPLICATION

**Table 22 Three-Phase Motor Specifications (60 Hz) 3450 rpm**

TYPE	MOTOR MODEL PREFIX	RATING					FULL LOAD		MAXIMUM LOAD		LINE TO LINE RESISTANCE OHMS	EFFICIENCY %		LOCKED ROTOR AMPS	KVA CODE
		HP	KW	VOLTS	HZ	S.F.	AMPS	WATTS	AMPS	WATTS		S.F.	F.L.		
4"	234501	1/2	0.37	200	60	1.6	2.8	585	3.4	860	6.6-8.4	70	64	17.5	N
	234511			230	60	1.6	2.4	585	2.9	860	9.5-10.9	70	64	15.2	N
	234541			380	60	1.6	1.4	585	2.1	860	23.2-28.6	70	64	9.2	N
	234521			460	60	1.6	1.2	585	1.5	860	38.4-44.1	70	64	7.6	N
	234531			575	60	1.6	1.0	585	1.2	860	58.0-71.0	70	64	6.1	N
	234502	3/4	0.55	200	60	1.5	3.6	810	4.4	1150	4.6-5.9	73	69	24.6	N
	234512			230	60	1.5	3.1	810	3.8	1150	6.8-7.8	73	69	21.4	N
	234542			380	60	1.5	1.9	810	2.5	1150	16.6-20.3	73	69	13	N
	234522			460	60	1.5	1.6	810	1.9	1150	27.2-30.9	73	69	10.7	N
	234532			575	60	1.5	1.3	810	1.6	1150	41.5-50.7	73	69	8.6	N
	234503	1	0.75	200	60	1.4	4.5	1070	5.4	1440	3.8-4.5	72	70	30.9	M
	234513			230	60	1.4	3.9	1070	4.7	1440	4.9-5.6	72	70	26.9	M
	234543			380	60	1.4	2.3	1070	2.8	1440	12.2-14.9	72	70	16.3	M
	234523			460	60	1.4	2	1070	2.4	1440	19.9-23.0	72	70	13.5	M
	234533			575	60	1.4	1.6	1070	1.9	1440	30.1-36.7	72	70	10.8	M
	234504	1.5	1.1	200	60	1.3	5.8	1460	6.8	1890	2.5-3.0	76	76	38.2	K
	234514			230	60	1.3	5	1460	5.9	1890	3.2-4.0	76	76	33.2	K
	234544			380	60	1.3	3	1460	3.6	1890	8.5-10.4	76	76	20.1	K
	234524			460	60	1.3	2.5	1460	3.1	1890	13.0-16.0	76	76	16.6	K
	234534			575	60	1.3	2	1460	2.4	1890	20.3-25.0	76	76	13.3	K
	234305	2	1.5	200	60	1.25	7.7	1960	9.3	2430	1.8-2.4	76	76	50.3	K
	234315			230	60	1.25	6.7	1960	8.1	2430	2.3-3.0	76	76	45.0	K
	234345			380	60	1.25	4.1	1960	4.9	2430	6.6-8.2	76	76	26.6	K
	234325			460	60	1.25	3.4	1960	4.1	2430	9.2-12.0	76	76	22.5	K
	234335			575	60	1.25	2.7	1960	3.2	2430	14.6-18.7	76	76	17.8	K
	234306	3	2.2	200	60	1.15	10.9	2920	12.5	3360	1.3-1.7	77	77	69.5	K
	234316			230	60	1.15	9.5	2920	10.9	3360	1.8-2.2	77	77	60.3	K
	234346			380	60	1.15	5.8	2920	6.6	3360	4.7-6.0	77	77	37.5	K
	234326			460	60	1.15	4.8	2920	5.5	3360	7.2-8.8	77	77	31.0	K
	234336			575	60	1.15	3.8	2920	4.4	3360	11.4-13.9	77	77	25.1	K
	234307	5	3.7	200	60	1.15	18.3	4800	20.5	5500	.68-.83	78	78	116	K
	234317			230	60	1.15	15.9	4800	17.8	5500	.91-1.1	78	78	102	K
234347	380			60	1.15	9.6	4800	10.8	5500	2.6-3.2	78	78	60.2	K	
234327	460			60	1.15	8.0	4800	8.9	5500	3.6-4.4	78	78	53.7	K	
234337	575			60	1.15	6.4	4800	7.1	5500	5.6-6.9	78	78	41.8	K	
234308	7.5	5.5	200	60	1.15	26.5	7150	30.5	8200	.43-.53	78	78	177	K	
234318			230	60	1.15	23.0	7150	26.4	8200	.60-.73	78	78	152	K	
234348			380	60	1.15	13.9	7150	16.0	8200	1.6-2.0	78	78	92.7	K	
234328			460	60	1.15	11.5	7150	13.2	8200	2.3-2.8	78	78	83.8	K	
234338			575	60	1.15	9.2	7150	10.6	8200	3.6-4.5	78	78	64.6	K	
234549	10	7.5	380	60	1.15	19.3	10000	21.0	11400	1.2-1.6	75	75	140	L	
234595			460	60	1.15	15.9	10000	17.3	11400	1.8-2.3	75	75	116.0	L	
234598			575	60	1.15	12.5	10000	13.6	11400	2.8-3.5	75	75	92.8	L	
234646	15	11	380	60	1.15	27.6	14600	31.2	16800	.86-1.1	77	76	178	J	
234626			460	60	1.15	22.8	14600	25.8	16800	1.2-1.5	77	76	147	J	
234636			575	60	1.15	18.2	14600	20.7	16800	1.9-2.4	77	76	118	J	

# Three-Phase Motors

## MOTOR APPLICATION

**Table 22A Three-Phase Motor Specifications (60 Hz) with a "G" suffix (i.e., 2343278602G) having a date code of 16X14 or newer**

TYPE	MOTOR MODEL PREFIX	RATING					FULL LOAD		MAXIMUM LOAD		(1) LINE-TO-LINE RESISTANCE (OHMS)	EFFICIENCY %		LOCKED ROTOR AMPS	KVA CODE
		HP	KW	VOLTS	HZ	S.F.	AMPS	WATTS	AMPS	WATTS	M= MAIN RESISTANCE S=START RESISTANCE	S.F.	F.L.		
4"	234501	1/2	0.37	200	60	1.6	2.8	580	3.4	865	7.7-9.4	69	64	16.0	N
	234511			230	60	1.6	2.4	580	2.9	865	9.8-12.0	69	64	13.9	N
	234541			380	60	1.6	1.4	580	2.1	865	26.1-31.9	69	64	8.4	N
	234521			460	60	1.6	1.2	580	1.5	865	39.5-48.2	69	64	7.0	N
	234531			575	60	1.6	1.0	580	1.2	865	56.0-68.4	69	64	5.6	N
	234502	3/4	0.55	200	60	1.5	3.6	820	4.4	1180	5.4-6.7	71	68	22.4	M
	234512			230	60	1.5	3.1	820	3.8	1180	7.0-8.6	71	68	19.5	M
	234542			380	60	1.5	1.9	820	2.5	1180	18.5-22.6	71	68	11.8	M
	234522			460	60	1.5	1.6	820	1.9	1180	28.4-34.7	71	68	9.7	M
	234532			575	60	1.5	1.3	820	1.6	1180	44.0-53.8	71	68	7.8	M
	234503	1	0.75	200	60	1.4	4.5	1060	5.4	1440	3.9-4.8	72	70	28.8	M
	234513			230	60	1.4	3.9	1060	4.7	1440	5.1-6.3	72	70	25.0	M
	234543			380	60	1.4	2.3	1060	2.8	1440	13.5-16.5	72	70	15.1	M
	234523			460	60	1.4	2	1060	2.4	1440	20.7-25.3	72	70	12.5	M
	234533			575	60	1.4	1.6	1060	1.9	1440	32.6-39.9	72	70	10.0	M
	234504	1.5	1.1	200	60	1.3	5.8	1475	6.8	1915	2.8-3.4	76	76	34.8	K
	234514			230	60	1.3	5	1475	5.9	1915	3.6-4.4	76	76	30.5	K
	234544			380	60	1.3	3	1475	3.6	1915	9.5-11.7	76	76	18.3	K
	234524			460	60	1.3	2.5	1475	3.1	1915	14.4-17.6	76	76	15.1	K
	234534			575	60	1.3	2	1475	2.4	1915	22.7-27.8	76	76	12.2	K
	234305	2	1.5	200	60	1.25	7.7	1935	9.3	2410	2.0-2.5	77	77	46.3	K
	234315			230	60	1.25	6.7	1935	8.1	2410	2.6-3.2	77	77	40.1	K
	234345			380	60	1.25	4.1	1935	4.9	2410	7.6-9.3	77	77	25.3	K
	234325			460	60	1.25	3.4	1935	4.1	2410	10.4-12.7	77	77	20.9	K
	234335			575	60	1.25	2.7	1935	3.2	2410	16.4-20.0	77	77	16.4	K
	234306	3	2.2	200	60	1.15	10.9	2870	12.5	3310	1.4-1.7	78	78	65.2	J
	234316			230	60	1.15	9.5	2870	10.9	3310	1.8-2.2	78	78	57.0	J
	234346			380	60	1.15	5.8	2870	6.6	3310	5.3-6.5	78	78	33.0	J
	234326			460	60	1.15	4.8	2870	5.5	3310	7.3-8.9	78	78	27.3	J
	234336			575	60	1.15	3.8	2870	4.4	3310	11.5-14.1	78	78	21.9	J
	234307	5	3.7	200	60	1.15	16.1	4710	18.8	5410	0.81-1.0	79	79	123	K
	234317			230	60	1.15	14.2	4710	16.4	5410	1.0-1.3	79	79	111	K
234347	380			60	1.15	8.6	4710	9.9	5410	2.9-3.6	79	79	67.1	K	
234327	460			60	1.15	7.1	4710	8.2	5410	4.2-5.1	79	79	55.4	K	
234337	575			60	1.15	5.7	4710	6.6	5410	6.2-7.6	79	79	45.9	L	
234308	7.5	5.5	200	60	1.15	24	7000	28.2	8020	0.50-0.61	80	80	193	K	
234318			230	60	1.15	21	7000	24.6	8020	0.67-0.82	80	80	171	L	
234348			380	60	1.15	12.7	7000	14.9	8020	1.9-2.3	80	80	104	L	
234328			460	60	1.15	10.5	7000	12.3	8020	2.7-3.3	80	80	87.9	L	
234338			575	60	1.15	8.2	7000	9.8	8020	4.1-5.0	81	81	71.0	L	
234549	10	7.5	380	60	1.15	16.1	9200	18.6	10620	1.5-1.9	81	81	127	K	
234595			460	60	1.15	13.3	9200	15.4	10620	2.2-2.7	81	81	105	K	
234598			575	60	1.15	10.7	9200	12.4	10620	3.5-4.3	81	81	81.6	K	

**NOTE:** Performance is typical, not guaranteed, at specified voltages. Performance at voltage ratings not shown is similar, except amps vary inversely with voltage.

# Three-Phase Motors

## MOTOR APPLICATION

**Table 22B Three-Phase Motor Specifications (60 Hz) 700 Series**

TYPE	MOTOR MODEL PREFIX	RATING					FULL LOAD		MAXIMUM LOAD		(1) LINE-TO-LINE RESISTANCE (OHMS)	EFFICIENCY %		LOCKED ROTOR AMPS	KVA CODE
		HP	KW	VOLTS	HZ	S.F.	AMPS	WATTS	AMPS	WATTS		S.F.	F.L.		
4"	234707	5	3.7	200	60	1.15	17.4	4870	19.8	5580	0.78-0.95	77	76	111	J
	234717			230	60	1.15	15.4	4870	17.4	5580	1.0-1.3	77	76	98.5	K
	234747			380	60	1.15	9.1	4820	10.4	5530	2.8-3.5	78	77	58.5	J
	234727			460	60	1.15	7.5	4820	8.6	5530	4.1-5.0	78	77	48.3	J
	234737			575	60	1.15	6.1	4820	6.9	5530	6.0-7.3	78	77	42.0	K
	234708	7.5	5.5	200	60	1.15	26.8	7190	30.0	8220	0.45-0.56	78	78	178	K
	234718			230	60	1.15	21.8	7130	24.8	8190	0.65-0.80	78	78	153	K
	234748			380	60	1.15	13.2	7100	15.0	8140	1.8-2.2	79	79	93.6	K
	234728			460	60	1.15	10.9	7100	12.4	8140	2.6-3.2	79	79	77.3	K
	234738			575	60	1.15	8.9	7035	10.1	8065	3.8-4.7	80	79	65.3	K
	234749	10	7.5	380	60	1.15	17.1	9455	19.7	10925	1.5-1.8	78	79	109	H
	234729			460	60	1.15	14.5	9375	16.5	10780	1.9-2.4	79	79	102	K
	234739			575	60	1.15	11.5	9550	13.2	11000	3.4-4.1	78	78	72.2	J

**NOTE:** Performance is typical, not guaranteed, at specified voltages. Performance at voltage ratings not shown is similar, except amps vary inversely with voltage.

# Three-Phase Motors

## MOTOR APPLICATION

**Table 23 Three-Phase Motor Fuse Sizing**

**NOTE:** Fuse and Beaker Sizing is the same for Franklin standard, "G" and Series "700" 4-inch motors.

TYPE	MOTOR MODEL PREFIX	RATING			CIRCUIT BREAKERS OR FUSE AMPS			CIRCUIT BREAKERS OR FUSE AMPS		
					(MAXIMUM PER NEC)			(TYPICAL SUBMERSIBLE)		
		HP	KW	VOLTS	STANDARD FUSE	DUAL ELEMENT TIME DELAY FUSE	CIRCUIT BREAKER	STANDARD FUSE	DUAL ELEMENT TIME DELAY FUSE	CIRCUIT BREAKER
<b>4"</b>	234501	<b>1/2</b>	<b>0.37</b>	200	10	5	8	10	4	15
	234511			230	8	4.5	6	8	4	15
	234541			380	5	2.5	4	5	2	15
	234521			460	4	2.25	3	4	2	15
	234531			575	3	1.8	3	3	1.4	15
	234502	<b>3/4</b>	<b>0.55</b>	200	15	7	10	12	5	15
	234512			230	10	5.6	8	10	5	15
	234542			380	6	3.5	5	6	3	15
	234522			460	5	2.8	4	5	3	15
	234532			575	4	2.5	4	4	1.8	15
	234503	<b>1</b>	<b>0.75</b>	200	15	8	15	15	6	15
	234513			230	15	7	10	12	6	15
	234543			380	8	4.5	8	8	4	15
	234523			460	6	3.5	5	6	3	15
	234533			575	5	2.8	4	5	2.5	15
	234504	<b>1.5</b>	<b>1.1</b>	200	20	12	15	20	8	15
	234514			230	15	9	15	15	8	15
	234544			380	10	5.6	8	10	4	15
	234524			460	8	4.5	8	8	4	15
	234534			575	6	3.5	5	6	3	15
	234305	<b>2</b>	<b>1.5</b>	200	25	15	20	25	11	20
	234315			230	25	12	20	25	10	20
	234345			380	15	8	15	15	6	15
	234325			460	15	6	10	11	5	15
	234335			575	10	5	8	10	4	15
	234306	<b>3</b>	<b>2.2</b>	200	35	20	30	35	15	30
	234316			230	30	17.5	25	30	12	25
	234346			380	20	12	15	20	8	15
	234326			460	15	9	15	15	6	15
	234336			575	15	7	10	11	5	15
	234307	<b>5</b>	<b>3.7</b>	200	60	35	50	60	25	50
	234317			230	50	30	40	45	20	40
	234347			380	30	17.5	25	30	12	25
	234327			460	25	15	20	25	10	20
	234337			575	20	12	20	20	8	20
	234308	<b>7.5</b>	<b>5.5</b>	200	90	50	70	80	35	70
234318	230			80	45	60	70	30	60	
234348	380			45	25	40	40	20	40	
234328	460			40	25	30	35	15	30	
234338	575			30	17.5	25	30	12	25	
234349	<b>10</b>	<b>7.5</b>	380	70	40	60	60	25	60	
234329			460	60	30	45	50	25	45	
234339			575	45	25	35	40	20	35	
234549			380	70	35	60	60	25	60	
234595			460	60	30	45	50	25	45	
234598	575	45	25	35	40	20	35			
234646	<b>15</b>	<b>11</b>	380	90	50	70	80	35	70	
234626			460	80	45	60	70	30	60	
234636			575	60	35	50	60	25	50	

# Three-Phase Motors

## MOTOR APPLICATION

**Table 24 Three-Phase Motor Specifications (60 Hz) 3450 rpm**

TYPE	MOTOR MODEL PREFIX	RATING					FULL LOAD		MAXIMUM LOAD		LINE TO LINE RESISTANCE OHMS	EFFICIENCY %		LOCKED ROTOR AMPS	KVA CODE
		HP	KW	VOLTS	HZ	S.F.	AMPS	WATTS	AMPS	WATTS		S.F.	F.L.		
<b>6" STD.</b>	236650	5	3.7	200	60	1.15	17.5	4700	20.0	5400	.77-.93	79	79	99	H
	236600			230	60	1.15	15	4700	17.6	5400	1.0-1.2	79	79	86	H
	236660			380	60	1.15	9.1	4700	10.7	5400	2.6-3.2	79	79	52	H
	236610			460	60	1.15	7.5	4700	8.8	5400	3.9-4.8	79	79	43	H
	236620			575	60	1.15	6	4700	7.1	5400	6.3-7.7	79	79	34	H
	236651	7.5	5.5	200	60	1.15	25.1	7000	28.3	8000	.43-.53	80	80	150	H
	236601			230	60	1.15	21.8	7000	24.6	8000	.64-.78	80	80	130	H
	236661			380	60	1.15	13.4	7000	15	8000	1.6-2.1	80	80	79	H
	236611			460	60	1.15	10.9	7000	12.3	8000	2.4-2.9	80	80	65	H
	236621			575	60	1.15	8.7	7000	9.8	8000	3.7-4.6	80	80	52	H
	236652	10	7.5	200	60	1.15	32.7	9400	37	10800	.37-.45	79	79	198	H
	236602			230	60	1.15	28.4	9400	32.2	10800	.47-.57	79	79	172	H
	236662			380	60	1.15	17.6	9400	19.6	10800	1.2-1.5	79	79	104	H
	236612			460	60	1.15	14.2	9400	16.1	10800	1.9-2.4	79	79	86	H
	236622			575	60	1.15	11.4	9400	12.9	10800	3.0-3.7	79	79	69	H
	236653	15	11	200	60	1.15	47.8	13700	54.4	15800	.24-.29	81	81	306	H
	236603			230	60	1.15	41.6	13700	47.4	15800	.28-.35	81	81	266	H
	236663			380	60	1.15	25.8	13700	28.9	15800	.77-.95	81	81	161	H
	236613			460	60	1.15	20.8	13700	23.7	15800	1.1-1.4	81	81	133	H
	236623			575	60	1.15	16.6	13700	19	15800	1.8-2.3	81	81	106	H
	236654	20	15	200	60	1.15	61.9	18100	69.7	20900	.16-.20	82	82	416	J
	236604			230	60	1.15	53.8	18100	60.6	20900	.22-.26	82	82	362	J
	236664			380	60	1.15	33	18100	37.3	20900	.55-.68	82	82	219	J
	236614			460	60	1.15	26.9	18100	30.3	20900	.8-1.0	82	82	181	J
	236624			575	60	1.15	21.5	18100	24.2	20900	1.3-1.6	82	82	145	J
	236655	25	18.5	200	60	1.15	77.1	22500	86.3	25700	.12-.15	83	83	552	J
	236605			230	60	1.15	67	22500	76.4	25700	.15-.19	83	83	480	J
	236665			380	60	1.15	41	22500	46	25700	.46-.56	83	83	291	J
	236615			460	60	1.15	33.5	22500	38.2	25700	.63-.77	83	83	240	J
	236625			575	60	1.15	26.8	22500	30	25700	1.0-1.3	83	83	192	J
	236656	30	22	200	60	1.15	90.9	26900	104	31100	.09-.11	83	83	653	J
	236606			230	60	1.15	79	26900	90.4	31100	.14-.17	83	83	568	J
	236666			380	60	1.15	48.8	26900	55.4	31100	.35-.43	83	83	317	J
	236616			460	60	1.15	39.5	26900	45.2	31100	.52-.64	83	83	284	H
	236626			575	60	1.15	31.6	26900	36.2	31100	.78-.95	83	83	227	J
	236667	40	30	380	60	1.15	66.5	35600	74.6	41400	.26-.33	83	83	481	J
236617	460			60	1.15	54.9	35600	62.9	41400	.34-.42	83	83	397	J	
236627	575			60	1.15	42.8	35600	49.6	41400	.52-.64	83	83	318	H	
236668	50	37	380	60	1.15	83.5	45100	95	52200	.21-.25	82	83	501	H	
236618			460	60	1.15	67.7	45100	77	52200	.25-.32	82	83	414	H	
236628			575	60	1.15	54.2	45100	61.6	52200	.40-.49	82	83	331	H	
276668			380	60	1.15	82.4	45100	94.5	52200	.21-.25	82	83	501	H	
276618			460	60	1.15	68.1	45100	78.1	52200	.25-.32	82	83	414	H	
276628	575	60	1.15	54.5	45100	62.5	52200	.40-.49	82	83	331	H			
276029	60/50	45/37	380	60	1.15	98.1	53500	111.8	61700	.15-.18	84	84	627	H	
276009			460	60	1.15	81.0	53500	92.3	61700	.22-.27	84	84	518	H	
276059			575	60	1.15	64.8	53500	73.9	61700	.35-.39	84	84	414	H	
236669	60	45	380	60	1.15	98.7	53500	111	61700	.15-.18	84	84	627	H	
236619			460	60	1.15	80.5	53500	91	61700	.22-.27	84	84	518	H	
236629			575	60	1.15	64.4	53500	72.8	61700	.35-.39	84	84	414	H	
276669			380	60	1.15	98.1	53500	111.8	61700	.15-.18	84	84	627	H	
276619			460	60	1.15	81.0	53500	92.3	61700	.22-.27	84	84	518	H	
276629	575	60	1.15	64.8	53500	73.9	61700	.35-.39	84	84	414	H			

Model numbers above are for three-lead motors. Six-lead motors with different model numbers have the same running performance, but when Wye connected for starting have locked rotor amps 33% of the values shown. Six-lead individual phase resistance = table X 1.5.

# Three-Phase Motors

## MOTOR APPLICATION

Table 25 6" Three-Phase Motor Specifications (60 Hz) 3450 rpm

TYPE	MOTOR MODEL PREFIX	RATING					FULL LOAD		MAXIMUM LOAD		LINE TO LINE RESISTANCE OHMS	EFFICIENCY %		LOCKED ROTOR AMPS	KVA CODE
		HP	KW	VOLTS	HZ	S.F.	AMPS	WATTS	AMPS	WATTS		S.F.	F.L.		
<b>6"</b> <b>HI-TEMP</b> <b>90 °C</b>	276650	5	3.7	200	60	1.15	17.2	5200	19.8	5800	.53 - .65	73	72	124	K
	276600			230	60	1.15	15.0	5200	17.2	5800	.68 - .84	73	72	108	K
	276660			380	60	1.15	9.1	5200	10.4	5800	2.0 - 2.4	73	72	66.0	K
	276610			460	60	1.15	7.5	5200	8.6	5800	2.8 - 3.4	73	72	54.0	K
	276620			575	60	1.15	6.0	5200	6.9	5800	4.7 - 5.7	73	72	43.0	K
	276651	7.5	5.5	200	60	1.15	24.8	7400	28.3	8400	.30 - .37	77	76	193	K
	276601			230	60	1.15	21.6	7400	24.6	8400	.41 - .50	77	76	168	K
	276661			380	60	1.15	13.1	7400	14.9	8400	1.1 - 1.4	77	76	102	K
	276611			460	60	1.15	10.8	7400	12.3	8400	1.7 - 2.0	77	76	84.0	K
	276621			575	60	1.15	8.6	7400	9.9	8400	2.6 - 3.2	77	76	67.0	K
	276652	10	7.5	200	60	1.15	32.0	9400	36.3	10700	.21 - .26	80	79	274	L
	276602			230	60	1.15	27.8	9400	31.6	10700	.28 - .35	80	79	238	L
	276662			380	60	1.15	16.8	9400	19.2	10700	.80 - .98	80	79	144	L
	276612			460	60	1.15	13.9	9400	15.8	10700	1.2 - 1.4	80	79	119	L
	276622			575	60	1.15	11.1	9400	12.7	10700	1.8 - 2.2	80	79	95.0	L
	276653	15	11	200	60	1.15	48.5	14000	54.5	15900	.15 - .19	81	80	407	L
	276603			230	60	1.15	42.2	14000	47.4	15900	.19 - .24	81	80	354	L
	276663			380	60	1.15	25.5	14000	28.7	15900	.52 - .65	81	80	214	L
	276613			460	60	1.15	21.1	14000	23.7	15900	.78 - .96	81	80	177	L
	276623			575	60	1.15	16.9	14000	19.0	15900	1.2 - 1.4	81	80	142	L
	276654	20	15	200	60	1.15	64.9	18600	73.6	21300	.10 - .12	80	80	481	K
	276604			230	60	1.15	56.4	18600	64.0	21300	.14 - .18	80	80	418	K
	276664			380	60	1.15	34.1	18600	38.8	21300	.41 - .51	80	80	253	K
	276614			460	60	1.15	28.2	18600	32.0	21300	.58 - .72	80	80	209	K
	276624			575	60	1.15	22.6	18600	25.6	21300	.93 - 1.15	80	80	167	K
	276655	25	18.5	200	60	1.15	80.0	22600	90.6	25800	.09 - .11	83	82	665	L
	276605			230	60	1.15	69.6	22600	78.8	25800	.11 - .14	83	82	578	L
	276665			380	60	1.15	42.1	22600	47.7	25800	.27 - .34	83	82	350	L
	276615			460	60	1.15	34.8	22600	39.4	25800	.41 - .51	83	82	289	L
	276625			575	60	1.15	27.8	22600	31.6	25800	.70 - .86	83	82	231	L
276656	30	22	200	60	1.15	95.0	28000	108.6	31900	.07 - .09	81	80	736	K	
276606			230	60	1.15	82.6	28000	94.4	31900	.09 - .12	81	80	640	K	
276666			380	60	1.15	50.0	28000	57.2	31900	.23 - .29	81	80	387	K	
276616			460	60	1.15	41.3	28000	47.2	31900	.34 - .42	81	80	320	K	
276626			575	60	1.15	33.0	28000	37.8	31900	.52 - .65	81	80	256	K	
276667	40	30	380	60	1.15	67.2	35900	76.0	42400	.18 - .23	84	83	545	L	
276617			460	60	1.15	55.4	35900	62.8	42400	.23 - .29	84	83	450	L	
276627			575	60	1.15	45.2	35900	50.2	42400	.34 - .43	84	83	360	L	

Model numbers above are for three-lead motors. Six-lead motors with different model numbers have the same running performance, but when Wye connected for starting have locked rotor amps 33% of the values shown. Six-lead individual phase resistance = table X 1.5.

# Three-Phase Motors

## MOTOR APPLICATION

Table 26 Three-Phase Motor Fuse Sizing

TYPE	MOTOR MODEL PREFIX		RATING			CIRCUIT BREAKERS OR FUSE AMPS			CIRCUIT BREAKERS OR FUSE AMPS		
	STD	HI-TEMP				(MAXIMUM PER NEC)			(TYPICAL SUBMERSIBLE)		
			HP	KW	VOLTS	STANDARD FUSE	DUAL ELEMENT TIME DELAY FUSE	CIRCUIT BREAKER	STANDARD FUSE	DUAL ELEMENT TIME DELAY FUSE	CIRCUIT BREAKER
<b>6"</b> <b>STD. &amp; HI-TEMP</b>	236650	276650	5	3.7	200	60	35	45	50	25	45
	236600	276600			230	45	30	40	45	20	40
	236660	276660			380	30	17.5	25	30	12	25
	236610	276610			460	25	15	20	25	10	20
	236620	276620			575	20	12	15	20	8	15
	236651	276651	7.5	5.5	200	80	45	70	80	35	70
	236601	276601			230	70	40	60	70	30	60
	236661	276661			380	45	25	35	40	20	35
	236611	276611			460	35	20	30	35	15	30
	236621	276621	575	30	17.5	25	25	11	25		
	236652	276652	10	7.5	200	100	60	90	100	45	90
	236602	276602			230	90	50	80	90	40	80
	236662	276662			380	60	35	45	50	25	45
	236612	276612			460	45	25	40	45	20	40
	236622	276622			575	35	20	30	35	15	30
	236653	276653	15	11	200	150	90	125	150	60	125
	236603	276603			230	150	80	110	125	60	110
	236663	276663			380	80	50	70	80	35	70
	236613	276613			460	70	40	60	60	30	60
	236623	276623	575	60	30	45	50	25	45		
	236654	276654	20	15	200	200	110	175	175	80	175
	236604	276604			230	175	100	150	175	70	150
	236664	276664			380	100	60	90	100	45	90
	236614	276614			460	90	50	70	80	35	70
	236624	276624			575	70	40	60	70	30	60
	236655	276655	25	18.5	200	250	150	200	225	100	200
	236605	276605			230	225	125	175	200	90	175
	236665	276665			380	125	80	110	125	50	110
	236615	276615			460	110	60	90	100	45	90
	236625	276625			575	90	50	70	80	35	70
	236656	276656	30	22	200	300	175	250	300	125	250
	236606	276606			230	250	150	225	250	100	200
236666	276666	380			150	90	125	150	60	125	
236616	276616	460			125	70	110	125	50	100	
236626	276626	575			100	60	90	100	40	80	
236667	276667	40	30	380	200	125	175	200	90	175	
236617	276617			460	175	100	150	175	70	150	
236627	276627			575	150	80	110	125	60	110	
236668	276668	50	37	380	250	150	225	250	110	225	
236618	276618			460	225	125	175	200	90	175	
236628	276628			575	175	100	150	175	70	150	
236669	276669	60	45	380	300	175	250	300	125	250	
236619	276619			460	250	150	225	250	100	225	
236629	276629			575	200	125	175	200	80	175	



# Three-Phase Motors

## MOTOR APPLICATION

**Table 27 Three-Phase Motor Specifications (60 Hz) 3525 rpm**

TYPE	MOTOR MODEL PREFIX	RATING					FULL LOAD		MAXIMUM LOAD		LINE TO LINE RESISTANCE OHMS	EFFICIENCY %		LOCKED ROTOR AMPS	KVA CODE
		HP	KW	VOLTS	HZ	S.F.	AMPS	KILOWATTS	AMPS	KILOWATTS		S.F.	F.L.		
<b>8" STD.</b>	239660	40	30	380	60	1.15	64	35	72	40	.16-.20	86	86	479	J
	239600			460	60	1.15	53	35	60	40	.24-.30	86	86	396	J
	239610			575	60	1.15	42	35	48	40	.39-.49	86	86	317	J
	239661	50	37	380	60	1.15	79	43	88	49	.12-.16	87	87	656	K
	239601			460	60	1.15	64	43	73	49	.18-.22	87	87	542	K
	239611			575	60	1.15	51	43	59	49	.28-.34	87	87	434	K
	239662	60	45	380	60	1.15	92	52	104	60	.09-.11	88	87	797	K
	239602			460	60	1.15	76	52	86	60	.14-.17	88	87	658	K
	239612			575	60	1.15	61	52	69	60	.22-.28	88	87	526	K
	239663	75	55	380	60	1.15	114	64	130	73.5	.06-.09	88	88	1046	L
	239603			460	60	1.15	94	64	107	73.5	.10-.13	88	88	864	L
	239613			575	60	1.15	76	64	86	73.5	.16-.21	88	88	691	L
	239664	100	75	380	60	1.15	153	85	172	97.5	.05-.06	89	89	1466	L
	239604			460	60	1.15	132	85	148	97.5	.07-.09	89	89	1211	L
	239614			575	60	1.15	101	85	114	97.5	.11-.13	89	89	969	L
	239165	125	93	380	60	1.15	202	109	228	125	.03-.04	87	86	1596	K
	239105			460	60	1.15	167	109	188	125	.05-.07	87	86	1318	K
	239115			575	60	1.15	134	109	151	125	.08-.11	87	86	1054	K
	239166	150	110	380	60	1.15	235	128	266	146	.02-.03	88	87	1961	K
	239106			460	60	1.15	194	128	219	146	.04-.05	88	87	1620	K
239116	575			60	1.15	164	128	182	146	.06-.08	88	87	1296	K	
239167	175	130	380	60	1.15	265	150	302	173	.02-.04	88	88	1991	J	
239107			460	60	1.15	219	150	249	173	.04-.05	88	88	1645	J	
239117			575	60	1.15	175	150	200	173	.06-.08	88	88	1316	J	
239168	200	150	380	60	1.15	298	169	342	194	.02-.03	88	88	2270	J	
239108			460	60	1.15	246	169	282	194	.03-.05	88	88	1875	J	
239118			575	60	1.15	197	169	226	194	.05-.07	88	88	1500	J	

**Table 27A 8" Three-Phase Motor Specifications (60 Hz) 3525 rpm**

TYPE	MOTOR MODEL PREFIX	RATING					FULL LOAD		MAXIMUM LOAD		LINE TO LINE RESISTANCE OHMS	EFFICIENCY %		LOCKED ROTOR AMPS	KVA CODE
		HP	KW	VOLTS	HZ	S.F.	AMPS	KILOWATTS	AMPS	KILOWATTS		S.F.	F.L.		
<b>8" HI-TEMP</b>	279160	40	30	380	60	1.15	69.6	38	78.7	43	.11-.14	79	78	616	M
	279100			460	60	1.15	57.5	38	65.0	43	.16-.19	79	78	509	M
	279110			575	60	1.15	46.0	38	52.0	43	.25-.31	79	78	407	M
	279161	50	37	380	60	1.15	84.3	47	95.4	53	.07-.09	81	80	832	M
	279101			460	60	1.15	69.6	47	78.8	53	.11-.14	81	80	687	M
	279111			575	60	1.15	55.7	47	63.0	53	.18-.22	81	80	550	M
	279162	60	45	380	60	1.15	98.4	55	112	62	.06-.07	83	82	1081	N
	279102			460	60	1.15	81.3	55	92.1	62	.09-.11	83	82	893	N
	279112			575	60	1.15	65.0	55	73.7	62	.13-.16	83	82	715	N
	279163	75	56	380	60	1.15	125	68	141	77	.05-.06	83	82	1175	L
	279103			460	60	1.15	100	68	114	77	.07-.09	83	82	922	L
	279113			575	60	1.15	80	68	92	77	.11-.14	83	82	738	L
	279164	100	75	380	60	1.15	159	88	181	100	.04-.05	86	85	1508	M
	279104			460	60	1.15	131	88	149	100	.05-.07	86	85	1246	M
	279114			575	60	1.15	105	88	119	100	.08-.10	86	85	997	M
	279165	125	93	380	60	1.15	195	109	223	125	.03-.04	86	85	1793	L
	279105			460	60	1.15	161	109	184	125	.04-.06	86	85	1481	L
	279115			575	60	1.15	129	109	148	125	.07-.09	86	85	1185	L
	279166	150	110	380	60	1.15	235	133	269	151	.02-.03	85	84	2012	K
	279106			460	60	1.15	194	133	222	151	.03-.05	85	84	1662	K
279116	575			60	1.15	155	133	178	151	.05-.07	85	84	1330	K	

Model numbers above are for three-lead motors. Six-lead motors with different model numbers have the same running performance, but when Wye connected for starting have locked rotor amps 33% of the values shown. Six-lead individual phase resistance = table X 1.5.

# Three-Phase Motors

## MOTOR APPLICATION

**Table 28 Three-Phase Motor Fuse Sizing**

TYPE	MOTOR MODEL PREFIX	RATING			CIRCUIT BREAKERS OR FUSE AMPS			CIRCUIT BREAKERS OR FUSE AMPS		
					(MAXIMUM PER NEC)			(TYPICAL SUBMERSIBLE)		
		HP	KW	VOLTS	STANDARD FUSE	DUAL ELEMENT TIME DELAY FUSE	CIRCUIT BREAKER	STANDARD FUSE	DUAL ELEMENT TIME DELAY FUSE	CIRCUIT BREAKER
<b>8" STD.</b>	239660	40	30	380	200	125	175	200	80	175
	239600			460	175	100	150	175	70	150
	239610			575	150	80	110	125	60	110
	239661	50	37	380	250	150	200	225	100	200
	239601			460	200	125	175	200	80	175
	239611			575	175	90	150	150	70	150
	239662	60	45	380	300	175	250	300	125	250
	239602			460	250	150	200	225	100	200
	239612			575	200	110	175	175	80	175
	239663	75	55	380	350	200	300	350	150	300
	239603			460	300	175	250	300	125	250
	239613			575	250	150	200	225	100	200
	239664	100	75	380	500	275	400	450	200	400
	239604			460	400	225	350	400	175	350
	239614			575	350	200	300	300	125	300
	239165	125	93	380	700	400	600	600	250	600
	239105			460	500	300	450	500	225	450
	239115			575	450	250	350	400	175	350
	239166	150	110	380	800	450	600	700	300	600
	239106			460	600	350	500	600	250	500
239116	575			500	300	400	450	200	400	
239167	175	130	380	800	500	700	800	350	700	
239107			460	700	400	600	700	300	600	
239117			575	600	350	450	600	225	450	
239168	200	150	380	1000	600	800	1000	400	800	
239108			460	800	450	700	800	350	700	
239118			575	600	350	500	600	250	500	

**Table 28A 8" Three-Phase Motor Fuse Sizing**

TYPE	MOTOR MODEL PREFIX	RATING			CIRCUIT BREAKERS OR FUSE AMPS			CIRCUIT BREAKERS OR FUSE AMPS		
					(MAXIMUM PER NEC)			(TYPICAL SUBMERSIBLE)		
		HP	KW	VOLTS	STANDARD FUSE	DUAL ELEMENT TIME DELAY FUSE	CIRCUIT BREAKER	STANDARD FUSE	DUAL ELEMENT TIME DELAY FUSE	CIRCUIT BREAKER
<b>8" HI-TEMP</b>	279160	40	30	380	225	125	175	200	90	175
	279100			460	175	110	150	175	70	150
	279110			575	150	90	125	125	60	125
	279161	50	37	380	250	150	225	225	110	225
	279101			460	200	125	175	200	90	175
	279111			575	175	100	150	150	70	150
	279162	60	45	380	300	175	250	300	125	250
	279102			460	275	150	225	250	100	225
	279112			575	200	125	175	175	80	175
	279163	75	56	380	400	200	350	350	150	350
	279103			460	300	175	275	300	125	275
	279113			575	275	150	225	225	100	225
	279164	100	75	380	500	300	450	450	200	450
	279104			460	400	250	350	400	175	350
	279114			575	350	200	300	300	125	300
	279165	125	93	380	700	400	600	600	250	600
	279105			460	500	300	450	500	225	450
	279115			575	450	250	350	400	175	350
	279166	150	110	380	800	450	600	700	300	600
	279106			460	600	350	500	600	250	500
279116	575			500	300	400	450	200	400	

# Three-Phase Motors

## MOTOR APPLICATION

### Overload Protection of Three-Phase Submersible Motors **Class 10 Protection Required**

Characteristics of submersible motors differ from standard surface motors and special overload protection is required. To provide sufficient protection against overloading and locked rotor conditions, the relay must meet the following characteristics:

- Must trip within 10 seconds or less at 500% of set current.
- Ultimately trip at 125% of set current.
- Protect against single phasing.
- Temperature compensating to avoid nuisance tripping.

The trip points must be met with the relay at -10 °C, room ambient and 50 °C temperatures.

Specific overload information can be obtained directly from the manufacturer's catalog. They are available from a Current/Time curve as shown.

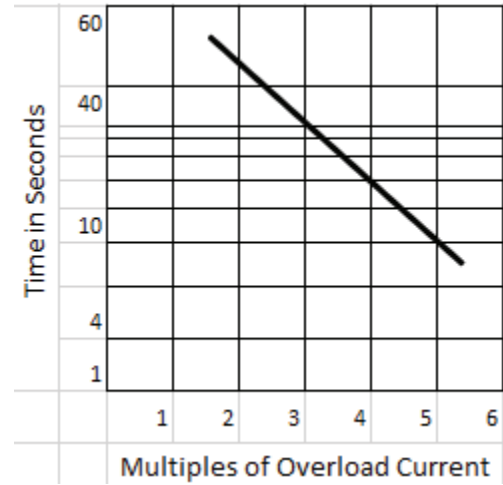

# Form 2207 – Action Facts

## SUBMERSIBLE MOTOR INSTALLATION RECORD

### INFORMATION SUPPLEMENT

#### 1.0 MOTOR

- 1.1 Verify motor nameplate data meets the application – hp, voltage, phase, and Hertz.
- 1.2 Check that the motor shaft rotates freely by hand on the second of two complete rotations. (On large motors, this usually requires a motor coupling with a cheater handle welded to it.)
- 1.3 Check that the motor lead assembly is not damaged.
- 1.4 Measure insulation resistance to ground at 500 volts – BEFORE SUBMERGED. It should be a minimum of 200 megohms or 200,000,000 ohms.
- 1.5 Measure insulation resistance to ground at 500 volts – AFTER SUBMERGED. It should be a minimum of 0.5 megohms or 500,000 ohms.
- 1.6 Verify the system is operating within the  $\pm 10\%$  of nameplate voltage requirement.
- 1.7 Verify the system will not ever operate in excess of the maximum amps indicated on the nameplate.
- 1.8 Verify the system is operating at 5% or less current unbalance.

#### Notice:

- If current unbalance exceeds 5%, the maximum operating amps must be derated to the nameplate Full Load Amps.
- Warning - System current unbalance can not exceed 10% without causing heating and mechanical wear issues.
- The submersible motor amperage % unbalance is typically 6x greater than its voltage % unbalance.
- Thus, 0.8% voltage unbalance = greater than 5% current unbalance, and 1.7% voltage unbalance = greater than 10% current unbalance.

#### 2.0 PUMP

- 2.1 Verify the pump nameplate and curve data meets the application hp, rpm, and flow/TDH requirements.
- 2.2 Verify the pump NPSH requirement will be met at all times.
- 2.3 Check that the pump shaft rotates freely by hand before installation.
- 2.4 Check that the pump shaft moves up about  $\frac{1}{4}$  inch when it is coupled to the motor.
- 2.5 Check that the pump guard is not pinching the motor leads, especially where it enters and exits the guard.

#### Notice:

- Pumps and motors 5 hp and above should be assembled in a vertical position to ensure correct alignment.
- A motor-pump assembly 5 hp and above should never be lifted from a non-vertical position by the pump discharge because it can bend the shaft in one or both of the products.

#### 3.0 POWER SUPPLY (3-PHASE)

- 3.1 Verify the transformer kVA rating is adequate for the motor per the Franklin Application (AIM) manual requirement.
- 3.2 Verify that all transformers have the same kVA rating.
- 3.3 Verify the 3-Phase pump panel fuses or its circuit breaker are correctly sized per the Franklin Application (AIM) manual requirement.
- 3.4 Verify the 3-Phase pump panel motor contactor is correctly sized per the Franklin Application (AIM) manual requirement.
- 3.5 Verify the 3-Phase pump panel motor overload is ambient compensated.
- 3.6 Verify the 3-Phase pump panel motor overload has a NEMA Class 10 trip curve.
- 3.7 Verify the 3-Phase pump panel motor overload heaters or its dial setting are correctly selected based on the system's operating point and not just arbitrarily set at the maximum motor operating amps.
- 3.8 At no time should the system operating amps or the motor overload system running point setting be higher than the motor nameplate maximum amp rating.

#### Notice:

- Electronic overloads should be set at the normal system operation point.
- Electronic overloads have a built-in multiplier of 115-125% times the input amps to determine the overload trip point.

#### 4.0 POWER SUPPLY (1-PHASE)

- 4.1 Verify the transformer kVA rating is adequate for the motor per the Franklin Application (AIM) manual requirement.

# Form 2207 – Action Facts

## SUBMERSIBLE MOTORS INSTALLATION RECORD

- 4.2 Verify the motor control box and the motor are made by the same manufacturer.
- 4.3 Verify the motor control box hp rating and its voltage match the motor rating exactly. If not, a premature failure of the control box or motor should be expected.

### 5.0 HIGH SURGE PROTECTION

- 5.1 Verify the submersible motor has a dedicated surge arrestor.  
All submersible motors require a dedicated surge arrestor.  
Motors 5 hp and smaller marked “Equipped with Lightning Arrestors”, have a built-in surge arrestor.
- 5.2 Verify the surge arrestor is mounted as close to the motor as practical.  
The location is usually in the pump panel, but sometimes it is placed at the well head in a separate electrical box.
- 5.3 Verify the surge arrestor is grounded below the lowest drawdown water level.  
This is usually accomplished by attaching the drop cable ground wire to the motor lead or the motor ground lug.
- 5.4 Verify the ground conductor size meets the minimum requirements of the National Electrical Code and all other relevant national, state, regional, and local codes.
- 5.5 Verify the motor is connected to both the electrical system ground and the motor.

### 6.0 ELECTRICAL DROP CABLE

- 6.1 Verify the temperature rating of the drop cable – typically 60 °C, 75 °C, 90 °C or 125 °C.
- 6.2 Verify if the cable is single conductor or jacketed conductor. Web cable is considered jacketed cable by regulating agencies.
- 6.3 Verify the conductor size – typically AWG, MCM or mm<sup>2</sup>.
- 6.4 Verify if the conductor material is copper; if not, determine the material and contact the factory for acceptability.
- 6.5 Verify the drop cable meets or exceeds the requirements of the Franklin Application (AIM) manual.

#### Notice:

- If the service entrance to pump panel or the pump panel to motor cable is not a copper material, contact the factory for the correct length derating factors.

### 7.0 MOTOR COOLING

- 7.1 Verify that the well water temperature does not exceed the maximum ambient temperature indicated on the nameplate of the motor.
- 7.2 Verify there is a minimum of 10 feet of clear water between the bottom of the motor and the bottom of the well.
- 7.3 Verify that all water entering the well is coming from below the lowest part of the motor.
- 7.4 Verify the system pumping rate will never deliver less flow than is required by the Franklin Application (AIM) manual to flow by-and-around the full length of the motor for cooling purposes.
- 7.5 Verify that 3-phase motors above 7.5 hp in a vertical potable water well should not exceed 100 starts in 24 hours and each start should include a minimum of 3 minutes ON and 10 minutes OFF.

#### Notice:

- If any water is entering the well above the lowest part of the motor, a flow sleeve is required.

### 8.0 MOTOR-PUMP INSTALLATION

- 8.1 Verify that the drop cable is supported to the drop pipe every 10 feet.
- 8.2 Verify at least one spring loaded (non-drilled) check valve is in the drop pipe.  
Preferably, the first check valve should be located at the top of the first pipe joint above the pump discharge (~20 feet) if the pump does not have a check built in to its discharge.
- 8.3 Verify all pipe joints are as tight as practical.  
The minimum torque should never be less than 10 foot-pounds times the motor nameplate hp rating.
- 8.4 Verify the rotation of the pump is correct.  
It is preferable to do this by checking the flow and current in both directions on 3-phase motors.  
This can be done by having the electrician swap any two leads.  
This is considered “best practice” since pumps under some conditions can supply amp readings and a visual flow observation that can be extremely misleading.

# Form 2207 - Page 1

## SUBMERSIBLE MOTORS INSTALLATION RECORD

RMA Number

KEY DEALER #

### DISTRIBUTOR

Name: \_\_\_\_\_  
 City: \_\_\_\_\_  
 State: \_\_\_\_\_ Zip: \_\_\_\_\_

### INSTALLER

Name: \_\_\_\_\_  
 City: \_\_\_\_\_  
 State: \_\_\_\_\_ Zip: \_\_\_\_\_

### END USER

Name: \_\_\_\_\_  
 City: \_\_\_\_\_  
 State: \_\_\_\_\_ Zip: \_\_\_\_\_

Well ID or GPS: \_\_\_\_\_ Water Temperature: \_\_\_\_\_ °F °C

Application/Water Use (e.g. potable water, irrigation, municipal, fountain, etc.): \_\_\_\_\_

Date Installed (mm/yy): \_\_\_\_\_ Date Failed (mm/yy): \_\_\_\_\_ Motor Position Shaft-Up: Yes No

Operating Cycle: ON Time Per Start \_\_\_\_\_ Hrs. Mins. Time OFF Between Stop & Restart \_\_\_\_\_ Hrs. Mins.

### MOTOR

Model: \_\_\_\_\_ Serial Number: \_\_\_\_\_ Date Code (if updated): \_\_\_\_\_

### MOTOR OVERLOAD

System Typical Operating Current: \_\_\_\_\_ Amps @ \_\_\_\_\_ Volts

Overload:  FE SubMonitor Input Amps \_\_\_\_\_ D3 Attached  Yes  No Fault Settings Attached  Yes  No

Other Manufacturer Model: \_\_\_\_\_ Dial Set at: \_\_\_\_\_ or Heater # \_\_\_\_\_

NEMA Class:  10  20  30 Ambient Compensated:  Yes  No

Power to Motor by:  Full Volt Starter  VFD  Soft Starter VFD or Soft Starter Mfr. & Model: \_\_\_\_\_

### PUMP

Manufacturer: \_\_\_\_\_

Model: \_\_\_\_\_

Stages: \_\_\_\_\_

Design Rating: \_\_\_\_\_ gpm @ \_\_\_\_\_ ft TDH

Horsepower Required by Pump End: \_\_\_\_\_

Actual Pump Delivery: \_\_\_\_\_ gpm @ \_\_\_\_\_ psi

What Controls When System Runs & Stops:

\_\_\_\_\_  
 (e.g. pressure, level, flow, manual on/off, timer, time clock etc.)

### YOUR NAME / DATE

\_\_\_\_\_ / \_\_\_\_\_

### WELL DATA (All measurements from well head down.)

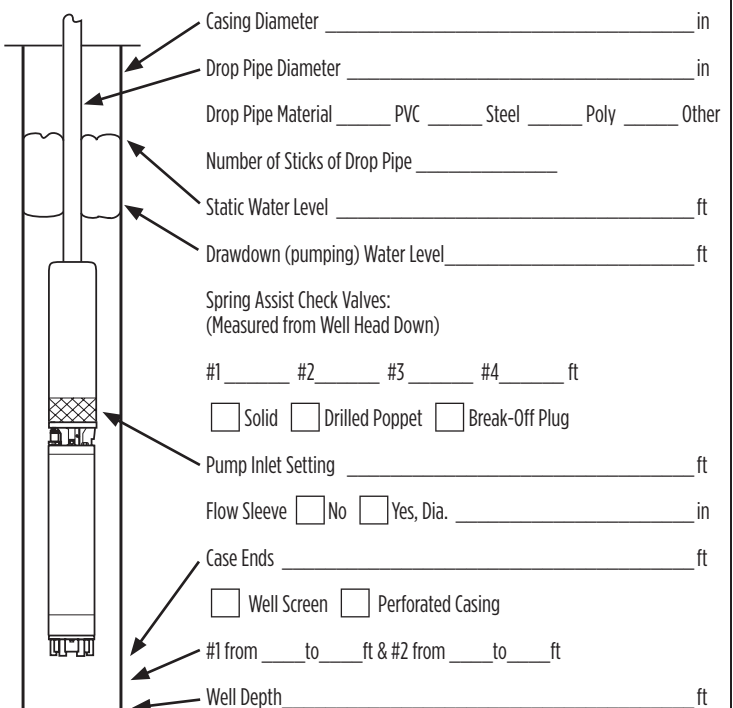

# Form 2207 - Page 2

RMA Number

## SUBMERSIBLE MOTORS INSTALLATION RECORD

### TRANSFORMERS

Number of Transformers:  Two  Three Transformers Supply Motor Only:  Yes  No  Unsure

Transformer #1: \_\_\_\_\_ kVA Transformer #2: \_\_\_\_\_ kVA Transformer #3: \_\_\_\_\_ kVA

### POWER CABLES & GROUND WIRE

#### Service Entrance to Pump Control Panel:

Length: \_\_\_\_\_ ft. & Gauge: \_\_\_\_\_ AWG/MCM

Material:  Copper  Aluminum Construction:  Jacketed  Individual Conductors  Web  Twisted

Temperature Rating of Cable:  60 °C  75 °C  90 °C  125 °C or Insulation Type: \_\_\_\_\_ (e.g. THHN)

#### Pump Control Panel to Motor:

Length: \_\_\_\_\_ ft. & Gauge: \_\_\_\_\_ AWG/MCM

Material:  Copper  Aluminum Construction:  Jacketed  Individual Conductors  Web  Twisted

Temperature Rating of Cable:  60 °C  75 °C  90 °C  125 °C or Insulation Type: \_\_\_\_\_ (e.g. THHN)

Ground Wire Size: From Control Panel to Motor: \_\_\_\_\_ AWG/MCM

Control Grounded to (mark all that apply):

Well Head  Metal Casing  Motor  Driven Rod  Power Supply

### INCOMING VOLTAGE

No Load L1-L2 \_\_\_\_\_ L2-L3 \_\_\_\_\_ L1-L3 \_\_\_\_\_

Full Load L1-L2 \_\_\_\_\_ L2-L3 \_\_\_\_\_ L1-L3 \_\_\_\_\_

### RUNNING AMPS & CURRENT BALANCE

Full Load L1 \_\_\_\_\_ L2 \_\_\_\_\_ L3 \_\_\_\_\_

% Unbalance: \_\_\_\_\_

### CONTROL PANEL

1 Pump Panel Manufacturer/Fabricator: \_\_\_\_\_

#### Short Circuit Protection - Fuses or Circuit Breaker

##### Option #1 - Fuse

Manufacturer: \_\_\_\_\_ Model: \_\_\_\_\_ Rating: \_\_\_\_\_ Amps

Type:  Time-Delay  Standard

##### Option #2 - Circuit Breaker

Manufacturer: \_\_\_\_\_ Model: \_\_\_\_\_ Rating: \_\_\_\_\_ Amps Setting: \_\_\_\_\_

#### Starter - Full Voltage, Reduced Voltage, Soft-Starter or VFD (Variable Frequency Drive)

##### Option #1 - Full Voltage

Manufacturer: \_\_\_\_\_ Model: \_\_\_\_\_ Size: \_\_\_\_\_ Contacts:  NEMA  IEC

##### Option #2 - Reduced Voltage

Manufacturer: \_\_\_\_\_ Model: \_\_\_\_\_ Ramp Time to Full Voltage: \_\_\_\_\_ sec.

##### Option #3 - Soft-Starter or VFD

Manufacturer: \_\_\_\_\_ Model: \_\_\_\_\_ Max. Continuous Amp Output Rating: \_\_\_\_\_

Min. Setting: \_\_\_\_\_ Hz & GPM: \_\_\_\_\_ Max. Setting: \_\_\_\_\_ Hz & GPM: \_\_\_\_\_

Start Ramp Time to 30 Hz: \_\_\_\_\_ sec. Stop Mode:  Power Off Coast  30-0 Hz Ramp \_\_\_\_\_ sec.

Special Output Filter Purchased:  Yes  No

Output Filter Manufacturer: \_\_\_\_\_ Model: \_\_\_\_\_ % Reactance: \_\_\_\_\_

4 Surge Arrestor:  No  Yes, Manufacturer: \_\_\_\_\_ Model: \_\_\_\_\_

# Booster Installation Record

## SUBMERSIBLE MOTOR

RMA Number

Date \_\_\_\_/\_\_\_\_/\_\_\_\_ Filled In By \_\_\_\_\_

### INSTALLATION

Owner/User \_\_\_\_\_ Telephone (\_\_\_\_) \_\_\_\_\_

Address \_\_\_\_\_ City \_\_\_\_\_ State \_\_\_\_\_ Zip \_\_\_\_\_

Installation Site, If Different \_\_\_\_\_

Contact \_\_\_\_\_ Telephone (\_\_\_\_) \_\_\_\_\_

System Application \_\_\_\_\_

System Manufactured By \_\_\_\_\_ Model \_\_\_\_\_ Serial No. \_\_\_\_\_

System Supplied By \_\_\_\_\_ City \_\_\_\_\_ State \_\_\_\_\_ Zip \_\_\_\_\_

Is this a "HERO" system (10.0 - 10.5 PH)?  Yes  No

### MOTOR

Model No. \_\_\_\_\_ Serial No. \_\_\_\_\_ Date Code \_\_\_\_\_

Horsepower \_\_\_\_\_ Voltage \_\_\_\_\_ Single-Phase Three-Phase Diameter \_\_\_\_\_ in.

Slinger Removed? Yes No Check Valve Plug Removed? Yes No

Motor Fill Solution Standard DI Water Model No. \_\_\_\_\_ Serial No. \_\_\_\_\_ Date Code \_\_\_\_\_

### PUMP

Manufacturer \_\_\_\_\_ Model \_\_\_\_\_ Serial No. \_\_\_\_\_

Stages \_\_\_\_\_ Diameter \_\_\_\_\_ Flow Rate Of \_\_\_\_\_ gpm At \_\_\_\_\_ TDH

Booster Case Internal Diameter \_\_\_\_\_ Material \_\_\_\_\_

### CONTROLS AND PROTECTIVE DEVICES

SubMonitor?  Yes  No If Yes, Warranty Registration No. \_\_\_\_\_

If Yes, Overload Set?  Yes  No Set At \_\_\_\_\_

Underload Sets?  Yes  No Set At \_\_\_\_\_

VFD or Reduced Voltage Starter?  Yes  No If Yes, Type \_\_\_\_\_

Mfr. \_\_\_\_\_ Setting \_\_\_\_\_ % Full Voltage In \_\_\_\_\_ sec

Pump Panel?  Yes  No If Yes, Mfr. \_\_\_\_\_ Size \_\_\_\_\_

Magnetic Starter/Contactor Mfr. \_\_\_\_\_ Model \_\_\_\_\_ Size \_\_\_\_\_

Heaters Mfr. \_\_\_\_\_ No. \_\_\_\_\_ If Adjustable Set At \_\_\_\_\_

Fuses Mfr. \_\_\_\_\_ Size \_\_\_\_\_ Type \_\_\_\_\_

Surge Arrestor Mfr. \_\_\_\_\_ Model \_\_\_\_\_

Controls Are Grounded to \_\_\_\_\_ with No. \_\_\_\_\_ Wire

Inlet Pressure Control  Yes  No If Yes, Mfr. \_\_\_\_\_ Model \_\_\_\_\_ Setting \_\_\_\_\_ psi Delay \_\_\_\_\_ sec

Inlet Flow Control  Yes  No If Yes, Mfr. \_\_\_\_\_ Model \_\_\_\_\_ Setting \_\_\_\_\_ gpm Delay \_\_\_\_\_ sec

Outlet Pressure Control  Yes  No If Yes, Mfr. \_\_\_\_\_ Model \_\_\_\_\_ Setting \_\_\_\_\_ psi Delay \_\_\_\_\_ sec

Outlet Flow Control  Yes  No If Yes, Mfr. \_\_\_\_\_ Model \_\_\_\_\_ Setting \_\_\_\_\_ gpm Delay \_\_\_\_\_ sec

Water Temperature Control  Yes  No If Yes, Mfr. \_\_\_\_\_ Model \_\_\_\_\_ Delay \_\_\_\_\_ sec

Set At \_\_\_\_\_ °F or \_\_\_\_\_ °C Located \_\_\_\_\_



# Booster Installation Record

## SUBMERSIBLE MOTOR

### INSULATION CHECK

Initial Megs: Motor & Lead Only      Black (T1/U1) \_\_\_\_\_      Yellow (T2/V1) \_\_\_\_\_      Red (T3/W1) \_\_\_\_\_  
Installed Megs: Motor, Lead, & Cable      Black (T1/U1) \_\_\_\_\_      Yellow (T2/V1) \_\_\_\_\_      Red (T3/W1) \_\_\_\_\_

### VOLTAGE TO MOTOR

Non-Operating:      B-Y (T1/U1 - T2/V1) \_\_\_\_\_      Y-R (T2/V1 - T3/W1) \_\_\_\_\_      R-B (T3/W1 - T1/U1) \_\_\_\_\_  
At Rated Flow of \_\_\_\_\_ gpm      B-Y (T1/U1 - T2/V1) \_\_\_\_\_      Y-R (T2/V1 - T3/W1) \_\_\_\_\_      R-B (T3/W1 - T1/U1) \_\_\_\_\_  
At Open Flow \_\_\_\_\_ gpm      B-Y (T1/U1 - T2/V1) \_\_\_\_\_      Y-R (T2/V1 - T3/W1) \_\_\_\_\_      R-B (T3/W1 - T1/U1) \_\_\_\_\_

### AMPS TO MOTOR

At Rated Flow of \_\_\_\_\_ gpm      Black (T1/U1) \_\_\_\_\_      Yellow (T2/V1) \_\_\_\_\_      Red (T3/W1) \_\_\_\_\_  
At Open Flow \_\_\_\_\_ gpm      Black (T1/U1) \_\_\_\_\_      Yellow (T2/V1) \_\_\_\_\_      Red (T3/W1) \_\_\_\_\_  
At Shut-Off\*      Black (T1/U1) \_\_\_\_\_      Yellow (T2/V1) \_\_\_\_\_      Red (T3/W1) \_\_\_\_\_

\*Do **NOT** run at Shut-Off more than two (2) minutes.

Inlet Pressure \_\_\_\_\_ psi      Outlet Pressure \_\_\_\_\_ psi      Water Temperature \_\_\_\_\_ °F or \_\_\_\_\_ °C

**If you have any questions or problems, call the Franklin Electric Toll-Free Hotline: 1-800-348-2420**

Comments: \_\_\_\_\_  
\_\_\_\_\_  
\_\_\_\_\_  
\_\_\_\_\_

### PLEASE SKETCH THE SYSTEM

# Three-Phase Motors

## MOTOR APPLICATION

### SubMonitor Three-Phase Protection

#### Applications

SubMonitor is designed to protect 3-phase pumps/motors with service factor amp ratings (SFA) from 5 to 350 A (approx. 3 to 200 hp). Current, voltage, and motor temperature are monitored using all three legs and allows the user to set up the SubMonitor quickly and easily.

#### Protects Against

- Under/Overload
- Under/Overtoltage
- Current Unbalance
- Overheated Motor (if equipped with Subtrol Heat Sensor)
- False Start (Chattering)
- Phase Reversal



This product is lead free.

### Power Factor Correction

In some installations, power supply limitations make it necessary or desirable to increase the power factor of a submersible motor. Table 32 lists the capacitive kVAR required to increase the power factor of large Franklin three-phase submersible motors to the approximate values shown at maximum input loading.

Capacitors must be connected on the line side of the overload relay, or overload protection will be lost.

**Table 32 kVAR Required 60 Hz**

MOTOR		KVAR REQUIRED FOR PF OF:		
HP	KW	0.90	0.95	1.00
5	3.7	1.2	2.1	4.0
7.5	5.5	1.7	3.1	6.0
10	7.5	1.5	3.3	7.0
15	11	2.2	4.7	10.0
20	15	1.7	5.0	12.0
25	18.5	2.1	6.2	15.0
30	22	2.5	7.4	18.0
40	30	4.5	11.0	24.0
50	37	7.1	15.0	32.0
60	45	8.4	18.0	38.0
75	55	6.3	18.0	43.0
100	75	11.0	27.0	60.0
125	93	17.0	36.0	77.0
150	110	20.0	42.0	90.0
175	130	9.6	36.0	93.0
200	150	16.0	46.0	110.0

Values listed are total required (not per phase).

# Three-Phase Motors

## MOTOR APPLICATION

### Three-Phase Starter Diagrams

Three-phase combination magnetic starters have two distinct circuits: a power circuit and a control circuit.

The power circuit consists of a circuit breaker or fused line switch, contacts, and overload heaters connecting incoming power lines L1, L2, L3 and the three-phase motor.

The control circuit consists of the magnetic coil, overload contacts, and a control device

such as a pressure switch. When the control device contacts are closed, current flows through the magnetic contactor coil, the contacts close, and power is applied to the motor. Hand-Off-Auto switches, start timers, level controls, and other control devices may also be in series in the control circuit.

#### Line Voltage Control

This is the most common type of control encountered. Since the coil is connected directly across the power lines L1 and L2, the coil must match the line voltage.

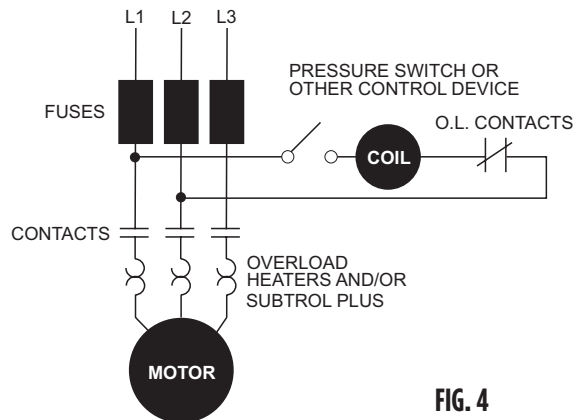

FIG. 4

#### Low Voltage Transformer Control

This control is used when it is desirable to operate push buttons or other control devices at some voltage lower than the motor voltage. The transformer primary must match the line voltage and the coil voltage must match the secondary voltage of the transformer.

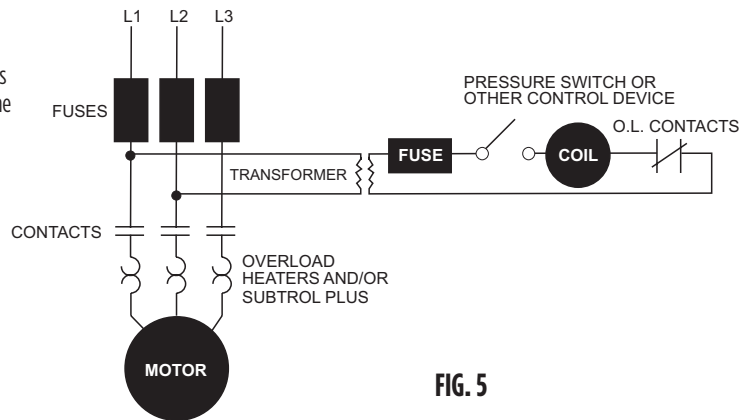

FIG. 5

#### External Voltage Controls

Control of a power circuit by a lower circuit voltage can also be obtained by connecting to a separate control voltage source. The coil rating must match the control voltage source, such as 115 or 24 volts.

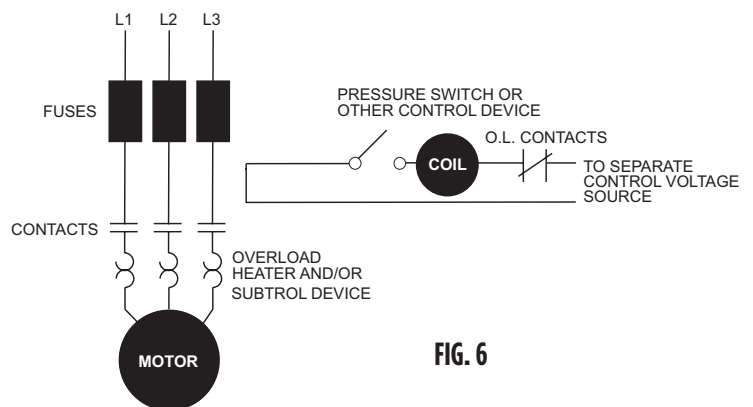

FIG. 6

# Three-Phase Motors

## MOTOR APPLICATION

### Three-Phase Power Unbalance

A full three-phase supply is recommended for all three-phase motors, consisting of three individual transformers or one three-phase transformer. So-called “open” Delta or Wye connections using only two transformers can be used, but are more likely to cause problems, such as poor performance, overload tripping or early motor failure due to current unbalance.

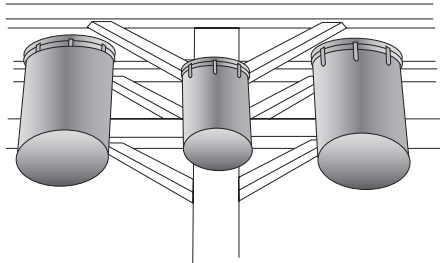

**FIG. 7**  
**FULL THREE-PHASE**

Transformer rating should be no smaller than listed in Table 4 for supply power to the motor alone.

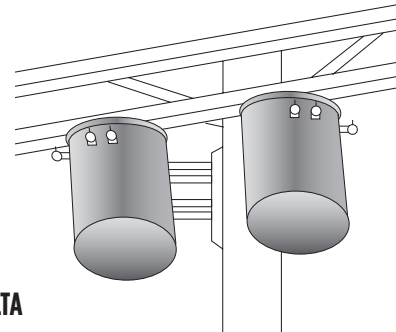

**FIG. 8**  
**OPEN DELTA**

### Checking and Correcting Rotation and Current Unbalance

- Establish correct motor rotation by running the motor in both directions. Normal rotation is CCW viewing the shaft end. Rotation can be changed by interchanging any two of the three motor leads. The rotation that gives the most water flow is typically the correct rotation.
- After correct rotation has been established, check the current in each of the three motor leads and calculate the current unbalance as explained in 3 below.  
If the current unbalance is 2% or less, leave the leads as connected.  
If the current unbalance is more than 2%, current readings should be checked on each leg using each of three possible hook-ups. Roll the motor leads across the starter in the same direction to prevent motor reversal.
- To calculate percent of current unbalance:
  - Add the three line amps values together
  - Divide the sum by three, yielding average current
  - Pick the amp value which is furthest from the average current (either high or low)
  - Determine the difference between this amp value (furthest from average) and the average
  - Divide the difference by the average. Multiply the result by 100 to determine percent of unbalance
- Current unbalance should not exceed 5% at max amp load or 10% at rated input load. If the unbalance cannot be corrected by rolling leads, the source of the unbalance must be located and corrected. If, on the three possible hookups, the leg farthest from the average stays on the same power lead, most of the unbalance is coming from the “power side” of the system. If the reading farthest from average moves with the same motor lead, the primary source of unbalance is on the “motor side” of the starter. In this instance, consider a damaged cable, leaking splice, poor connection, or faulty motor winding.

#### Phase designation of leads for CCW rotation viewing shaft end.

To reverse rotation, interchange any two leads.

Phase 1 or “A” - Black, T1, or U1

Phase 2 or “B” - Yellow, T2, or V1

Phase 3 or “C” - Red, T3, or W1

**NOTICE:** Phase 1, 2, and 3 may not be L1, L2, and L3.

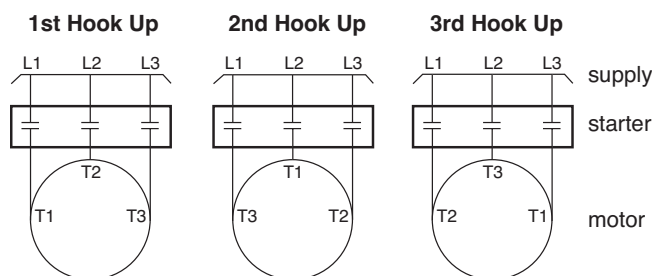

#### EXAMPLE:

T1 = 51 amps	T3 = 50 amps	T2 = 50 amps
T2 = 46 amps	T1 = 49 amps	T3 = 48 amps
+ T3 = 53 amps	+ T2 = 51 amps	+ T1 = 52 amps
Total = 150 amps	Total = 150 amps	Total = 150 amps
$\frac{150}{3} = 50$ amps	$\frac{150}{3} = 50$ amps	$\frac{150}{3} = 50$ amps
50 - 46 = 4 amps	50 - 49 = 1 amp	50 - 48 = 2 amps
$\frac{4}{50} = 0.08$ or 8%	$\frac{1}{50} = 0.02$ or 2%	$\frac{2}{50} = 0.04$ or 4%

# Three-Phase Motors

## MOTOR APPLICATION

### Three-Phase Motor Lead Identification

#### Line Connections — Six-Lead Motors

**WARNING:** When installing 6-lead motors extra care must be used to ensure lead identification at the surface. Leads must be marked and connected per diagram. Motor leads are not connected red to red, yellow to yellow, etc.

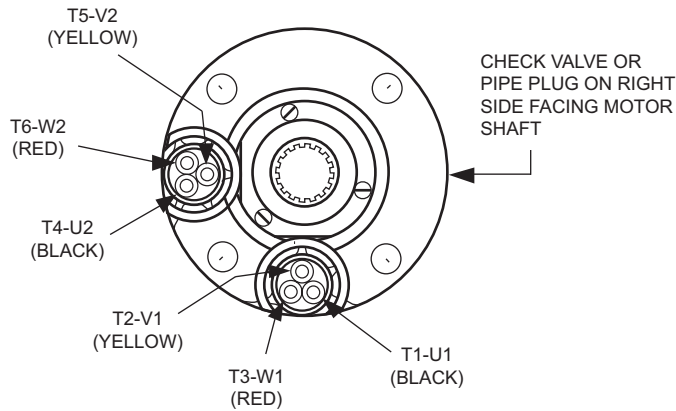

LEADS LOCATED HERE ONLY FOR 3 LEAD (DOL) MOTORS

#### 90° Lead Spacing

Connections for across-the-line starting, running, and any reduced voltage starting except WYE-DELTA type starters.

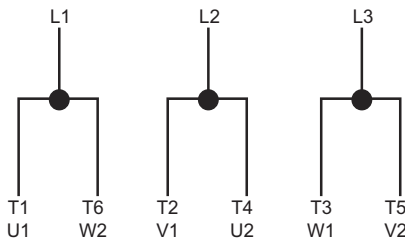

WYE-DELTA starters connect the motor as shown below during starting, then change to the running connection shown at the left.

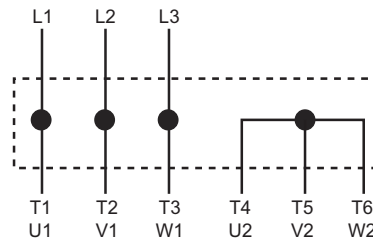

Each motor lead is numbered with two markers, one near each end. To reverse rotation, interchange any two line connections.

### Phase Converters

There are a number of different types of phase converters available. Each generates three-phase power from a single-phase power line.

In all phase converters, the voltage balance is critical to current balance. Although some phase converters may be well balanced at one point on the system-operating curve, submersible pumping systems often operate at differing points on the curve as water levels and operating pressures fluctuate. Other converters may be well balanced at varying loads, but their output may vary widely with fluctuations in the input voltage.

The following guidelines have been established for submersible installations to be warrantable when used with a phase converter.

1. Limit pump loading to rated horsepower. Do not load into motor service factor.
2. Maintain at least 3 ft/s flow past the motor. Use a flow sleeve when necessary.
3. Use time delay fuses or circuit breakers in pump panel. Standard fuses or circuit breakers do not provide secondary motor protection.
4. SubMonitor will not work with electronic solid state or electro mechanical phase converters.
5. Current unbalance must not exceed 10%.

# Three-Phase Motors

## MOTOR APPLICATION

### Reduced Voltage Starters

All Franklin three-phase submersible motors are suitable for full-voltage starting. Under this condition the motor speed goes from zero to full speed within a half second or less. The motor current goes from zero to locked rotor amps, then drops to running amps at full speed. This may dim lights, cause momentary voltage dips to other electrical equipment, and shock power distribution transformers.

In some cases the power companies may require reduced-voltage starters to limit this voltage dip. There are also times when reduced-voltage starters may be desirable to reduce motor starting torque thus reducing the stress on shafts, couplings, and discharge piping. Reduced-voltage starters also slow the rapid acceleration of the water on start-up to help control upthrust and water hammer.

Reduced-voltage starters may not be required if the maximum recommended cable length is used. With maximum recommended cable length there is a 5% voltage drop in the cable at running amps, resulting in about 20% reduction in starting current and about 36% reduction in starting torque compared to having rated voltage at the motor. This may be enough reduction in starting current so that reduced-voltage starters are not required.

**Three-Lead Motors:** Autotransformer or solid-state reduced-voltage starters may be used for soft-starting standard three-phase motors.

When autotransformer starters are used, the motor should be supplied with at least 55% of rated voltage to ensure adequate starting torque. Most autotransformer starters have 65% and 80% taps. Setting the taps on these starters depends on the percentage of the maximum allowable cable length used in the system. If the cable length is less than 50% of the maximum allowable, either the 65% or the 80% taps may be used. When the cable length is more than 50% of allowable, the 80% tap should be used.

### Inline Booster Pump Systems

Franklin Electric offers three different types of motors for non-vertical applications.

1. The **Booster** motors are specifically designed for booster applications. They are the **“Best Choice” for sealed Reverse Osmosis applications**. These motors are the result of two years of focused development and bring additional value and durability to booster module systems. These motors are only available to OEMs or Distributors who have demonstrated capability in Booster Module systems design and operation and adhere to Franklin’s Application Manual requirements.
2. The **Hi-Temp** motors have many of the internal design features of the Booster motor. It’s additional length allows for higher temperature handling and the Sand Fighter sealing system provides greater abrasion resistance. One or both of these conditions are often experienced in open atmosphere applications such as lakes, ponds, etc.

**Six-Lead Motors:** Wye-Delta starters are used with six-lead Wye-Delta motors. All Franklin 6” and 8” three-phase motors are available in six-lead Wye-Delta construction. Consult the factory for details and availability. Part winding starters are not compatible with Franklin Electric submersible motors and should not be used.

Wye-Delta starters of the open-transition type, which momentarily interrupt power during the starting cycle, are not recommended. Closed-transition starters have no interruption of power during the start cycle and can be used with satisfactory results.

**Reduced-voltage starters have adjustable settings for acceleration ramp time, typically preset at 30 seconds. They must be adjusted so the motor is at full voltage within THREE SECONDS MAXIMUM to prevent excessive radial and thrust bearing wear.**

**If Subtrol-Plus or SubMonitor is used the acceleration time must be set to TWO SECONDS MAXIMUM due to the 3 second reaction time of the Subtrol-Plus or SubMonitor.**

**Solid-state starters AKA soft starts may not be compatible with Subtrol-Plus/ SubMonitor. However, in some cases a bypass contactor has been used. Consult the factory for details.**

**During shutdown, Franklin Electric’s recommendation is for the power to be removed, allowing the pump/motor to coast down. Stopping the motor by ramping down the voltage is possible, but should be limited to three (3) seconds maximum.**

**CAUTION: Do not use a Reduced Voltage Starter with a minimum sized generator. Both items drop the output voltage and combining these items causes the potential for severe motor damage and equipment failure due to low voltage.**

3. The **Standard Vertical Water Well** (40-125 hp) motors can be adapted to non-vertical applications when applied per the below guidelines. However, they will be more sensitive to application variances than the other two designs.

All of the above motors must be applied per the guidelines listed below. In addition, for all applications where the motor is applied in a sealed system, a Submersible Motor Booster Installation Record (Form 3655) or its equivalent must be completed at start-up and received by Franklin Electric within 60 days. A sealed system is one where the motor and pump intake are mounted in a sleeve and the water feeding the pump intake is not open to the atmosphere.

Continued on next page

# Three-Phase Motors

## MOTOR APPLICATION

### Inline Booster Pump Systems (Continued)

#### Design And Operational Requirements

- Non-Vertical Operation:** Vertical Shaft-up (0°) to Horizontal (90°) operation is acceptable as long as the pump transmits “down-thrust” to the motor within 3 seconds after start-up and continuously during operation. However, it is best practice to provide a positive slope whenever it is possible, even if it is only a few degrees.
- Motor, Sleeve, and Pump Support System:** The booster sleeve ID must be sized according to the motor cooling and pump NPSHR requirements. The support system must support the motor’s weight, prevent motor rotation, and keep the motor and pump aligned. The support system must also allow for thermal axial expansion of the motor without creating binding forces.
- Motor Support Points:** A minimum of two support points are required on the motor. One in the motor/pump flange connection area and one in the bottom end of the motor area. The motor castings, not the shell area, are recommended as support points. If the support is a full length support and/or has bands in the shell area, they must not restrict heat transfer or deform the shell.
- Motor Support Material and Design:** The support system shall not create any areas of cavitation or other areas of reduced flow less than the minimum rate required by this manual. They should also be designed to minimize turbulence and vibration and provide stable alignment. The support materials and locations must not inhibit the heat transfer away from the motor.
- Motor and Pump Alignment:** The maximum allowable misalignment between the motor, pump, and pump discharge is 0.025 inch per 12 inches of length (2 mm per 1000 mm of length). This must be measured in both directions along the assembly using the motor/pump flange connection as the starting point. The booster sleeve and support system must be rigid enough to maintain this alignment during assembly, shipping, operation, and maintenance.
- Lubrication and Heat Resistance:** The best motor lubrication and heat resistance is obtained with the factory based propylene glycol fill solution. Only when an application MUST HAVE deionized (DI) water should the factory fill solution be replaced. When a deionized water fill is required, the motor must be derated as indicated on the below chart. The exchange of the motor fill solution to DI water must be done by an approved Franklin service shop or representative using a vacuum fill system per Franklin’s Motor Service Manual instruction. The motor shell then must be permanently stamped with a DI closely behind the Serial Number.

The maximum pressure that can be applied to the motor internal components during the removal of the factory fill solution is 7 psi (0.5 bar.)

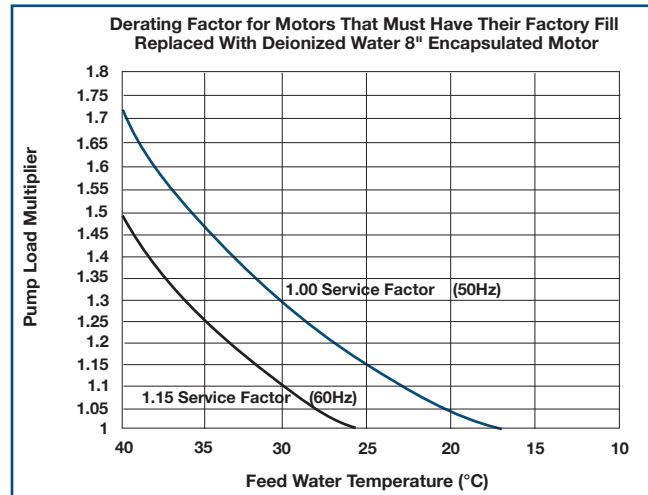

FIG. 9

- First:** Determine maximum Feed Water Temperature that will be experienced in this application. If the feed water exceeds the maximum ambient of the motor, both the DI water derating and a hot water application derating must be applied.
- Second:** Determine the Pump Load Multiplier from the appropriate Service Factor curve. (Typical 1.15 Service Factor is for 60 Hz ratings & 1.00 Service Factor for 50 Hz ratings).
- Third:** Multiply the Pump Load Requirement times the pump load multiplier number indicated on the vertical axis to determine the Minimum Motor Nameplate Rating.
- Fourth:** Select a motor with a nameplate equal or higher than the above calculated value.
- Motor Alterations - Sand Slinger & Check Valve Plug:** On 6” and 8” motors, the rubber sand slinger located on the shaft must be removed. If a pipe plug is covering the check valve, it must be removed. The special Booster motor already has these modifications.
- Frequency of Starts:** Fewer than 10 starts per 24-hour period are recommended. Allow at least 20 minutes between shutdown and start-up of the motor.
- Controls-Soft Starters and VFDs:** Reduced voltage starters and variable speed drives (inverter drives) may be used with Franklin three-phase submersible motors to reduce starting current, upthrust, and mechanical stress during start-up. The guidelines for their use with submersible motors are different than with normal air cooled motor applications. Refer to the Franklin Electric Application, Installation, and Maintenance (AIM) manual Reduced Voltage Starters section or Variable Speed Submersible Pump Operation, Inverter Drives sections for specific details including required filtering.

# Three-Phase Motors

## MOTOR APPLICATION

### Inline Booster Pump Systems (Continued)

10. **Motor Overload Protection:** Submersible motors require properly sized ambient compensated Class 10 quick-trip overloads per Franklin's AIM manual guidelines to protect the motor. Class 20 or higher overloads are NOT acceptable. Franklin's SubMonitor is strongly recommended for all large submersibles since it is capable of sensing motor heat without any additional wiring to the motor. Applications using Soft Starters with a SubMonitor require a start-up bypass - consult the factory for details. SubMonitor can not be used in applications using a VFD control.
11. **Motor Surge Protection:** Properly sized, grounded, and dedicated motor surge arrestors must be installed in the supply line of the booster module as close to the motor as possible. This is required on all systems including those using soft-starters and variable speed drives (inverter drives).
12. **Wiring:** Franklin's lead assemblies are only sized for submerged operation in water to the motor nameplate maximum ambient temperature and may overheat and cause failure or serious injury if operated in air. Any wiring not submerged must meet applicable national and local wiring codes and Franklin Cable Chart Tables 16-21. (Notice: wire size, wire rating, and insulation temperature rating must be known when determining its suitability to operate in air or conduit. Typically, for a given size and rating, as the insulation temperature rating increases its ability to operate in air or conduit also increases.)
13. **Check Valves:** Spring-loaded check valves must be used on start-up to minimize motor upthrusting, water hammer, or in multiple booster (parallel) applications to prevent reverse flow.
14. **Pressure Relief Valves:** A pressure relief valve is required and must be selected to ensure that, as the pump approaches shut-off, it never reaches the point that the motor will not have adequate cooling flow past it.
15. **System Purge (Can Flooding):** An air bleeder valve must be installed on the booster sleeve so that flooding may be accomplished prior to booster start-up. Once flooding is complete, the booster should be started and brought up to operating pressure as quickly as possible to minimize the duration of an upthrust condition. At no time should air be allowed to gather in the booster sleeve because this will prevent proper cooling of the motor and permanently damage it.
16. **System Flush – Must Not Spin Pump:** Applications may utilize a low flow flushing operation. Flow through the booster sleeve must not spin the pump impellers and the motor shaft. If spinning takes place, the bearing system will be permanently damaged and the motor life shortened. Consult the booster pump manufacturer for maximum flow rate through the pump when the motor is not energized.
17. **Open Atmosphere Booster Pump Systems:** When an open booster is placed in a lake, tank, etc. that is open to atmospheric pressure, the water level must provide sufficient head pressure to allow the pump to operate above its NPSHR requirement at all times and all seasons. Adequate inlet pressure must be provided prior to booster start-up.

**Table 38 Franklin Cable Chart (See item 12 Wiring above)**

CABLE TEMP. RATING (°C)	MOTOR NAMEPLATE RATED AMPS FULL LOAD	#10 AWG		#8 AWG		#6 AWG		#4 AWG		#2 AWG	
		IN AIR	IN CONDUIT	IN AIR	IN CONDUIT	IN AIR	IN CONDUIT	IN AIR	IN CONDUIT	IN AIR	IN CONDUIT
75	3-LEAD (DOL)	40A	28A	56A	40A	76A	52A	100A	68A	136A	92A
	6-LEAD (Y-Δ)	69A	48A	97A	69A	132A	90A	173A	118A	236A	159A
90	3-LEAD (DOL)	44A	32A	64A	44A	84A	60A	112A	76A	152A	104A
	6-LEAD (Y-Δ)	76A	55A	111A	76A	145A	104A	194A	132A	263A	180A
125	3-LEAD (DOL)	66A	46A	77A	53A	109A	75A	153A	105A	195A	134A
	6-LEAD (Y-Δ)	114A	80A	133A	91A	188A	130A	265A	181A	337A	232A

Based on 30 °C maximum ambient with cable length of 100 feet or less.

Continued on next page



# Three-Phase Motors

## MOTOR APPLICATION

### Inline Booster Pump Systems (Continued)

#### Four Continuous Monitoring System Requirements for Sealed Booster Systems.

1. **Water Temperature:** Feed water on each booster must be continuously monitored and not allowed to exceed the motor nameplate maximum ambient temperature at any time. IF THE INLET TEMPERATURE EXCEEDS THE MOTOR NAMEPLATE MAXIMUM AMBIENT TEMPERATURE, THE SYSTEM MUST SHUTDOWN IMMEDIATELY TO PREVENT PERMANENT MOTOR DAMAGE. If feed water temperatures are expected to be above the allowable temperature, the motor must be derated. See Franklin's AIM manual Hot Water Applications section for derating guidelines. (The high temperature feed water derating is in addition to the exchange to DI water derating if the motor factory fill solution was exchanged to DI water.)
2. **Inlet Pressure:** The inlet pressure on each booster module must be continuously monitored. It must always be positive and higher than the NPSHR (Net Positive Suction Head Requirement) of the pump. A minimum of 20 PSIG (1.38 Bar) is required at all times, except for 10 seconds or less when the motor is starting and the system is coming up to pressure. Even during these 10 seconds the pressure must remain positive and be higher than the NPSHR (Net Positive Suction Head Requirement) of the pump.

PSIG is the actual value displayed on a pressure gauge in the system piping. PSIG is the pressure above the atmospheric conditions. If at any time these pressure requirements are not being met, the motor must be de-energized immediately to prevent permanent damage to the motor. Once the motor is damaged, it is usually not immediately noticeable, but progresses and results in a premature motor failure weeks or months after the damage occurred.

Motors that will be exposed to pressure in excess of 500 psi (34.47 Bar) must undergo special high pressure testing. Consult factory for details and availability.

3. **Discharge Flow:** The flow rate for each pump must not be allowed to drop below the motor minimum cooling flow requirement. IF THE MOTOR MINIMUM COOLING FLOW REQUIREMENT IS NOT BEING MET FOR MORE THAN 10 SECONDS, THE SYSTEM MUST BE SHUT DOWN IMMEDIATELY TO PREVENT PERMANENT MOTOR DAMAGE.
4. **Discharge Pressure:** The discharge pressure must be monitored to ensure that a downthrust load toward the motor is present within 3 seconds after start-up and continuously during operation. IF THE MOTOR DISCHARGE PRESSURE IS NOT ADEQUATE TO MEET THIS REQUIREMENT, THE SYSTEM MUST BE SHUT DOWN IMMEDIATELY TO PREVENT PERMANENT MOTOR DAMAGE.

# Three-Phase Motors

## MOTOR APPLICATION

### Variable Frequency Drive Submersible Motor Requirements

Franklin Electric's three-phase, encapsulated submersible motors can be used with variable frequency drives (VFDs) when applied within the guidelines below.

All three-phase, encapsulated submersible motors must have the VFD sized based on the motor's nameplate maximum amps, not horsepower. The continuous rated amps of the VFD must be equal to or greater than the motor's nameplate maximum amps or warranty will be void.

Franklin Electric's single-phase, 2- and 3-wire, encapsulated submersible motors can only be used with the appropriate Franklin constant pressure controller.

**NOTE:** Warranty on Franklin 2-wire motors is void if applied on non-Franklin VFDs.

Franklin Electric's submersible motor Application, Installation, Maintenance (AIM) manual should be checked for the latest guidelines and can be found online at [www.franklin-electric.com](http://www.franklin-electric.com).

**WARNING:** There is a potential shock hazard from contact with and/or touching the insulated cables connected to the variable frequency drive output anytime the motor has energy applied.

### Output Filter Requirement Test:

**NOTICE:** An incoming power supply or line-side filter for the drive does not replace the need for additional output filters.

**An output filter is required if the answer is yes to both of the items below:**

- #1 - Is the motor nameplate voltage more than 379 Volts?
- #2 - Is the cable from drive-to-motor more than 50 ft (15.2 m)?

**NOTICE:** More than 99% of the drives applied on water well submersible motors will require the purchase of additional output filtering based on the questions above.

Output filters can be expensive. However, when needed, it is required for the motor to be considered for warranty. Make sure this item is not overlooked when quoting a job.

### Filtering Guidelines:

Filters should be recommended by the drive manufacturer.

Franklin Electric has a line of VFDs that are specifically designed for Franklin systems. These VFDs are used in the MonoDrive and SubDrive constant pressure systems. The Franklin MonoDrive and SubDrive systems already have the required additional output filtering installed.

For other Franklin Electric VFD products, follow the filter requirements as recommended in the product manuals.

### Filter Sizing:

As mentioned, Filters should be recommended by the drive manufacturer. For correct recommendations, provide them with the answers to the six items below.

#### REQUIRED ITEMS FOR PROPER VFD FILTER SIZING:

(1) VFD model (2) Carrier frequency setting (3) Motor nameplate voltage (4) Motor nameplate max amps (5) Cable length from the drive output terminals to the motor (6) Motor operating frequency or hertz.

### Types of Filters & Reactors:

For submersible applications, typical installations use either a reactor, DV/DT filter, or Sine Wave filter. While a Sine Wave filter is generally best, it is not always required.

A resistor-inductor-capacitor (RLC) filter has both a high pass filter & a low pass filter section and are considered the best practice, but a low pass reactor filter is also acceptable in some cases

PWM (Pulse Width Modulated) DV/DT value can be defined as: the rate at which voltage is changing with time or how fast the voltage is accelerating. This information can be supplied by the drive manufacturer or the manufacturer's drive specification sheet. The DV/DT value cannot be measured with typical field equipment, even when using a true-RMS voltage/ampereage multi-meter.

For suggestions on DV/DT and Sine Wave filters, see chart:

VFD OUTPUT FILTERING REQUIREMENTS				
MOTOR VOLTAGE RATING	INPUT VOLTAGE	MOTOR CABLE LENGTH	OUTPUT FILTER RECOMMENDED	RECOMMENDED VFD CARRIER FREQUENCY
< 380V AC	< 342V AC	N/A	NONE	2KHZ
> 342V AC – 575V AC	< 632V AC	< 50'		
		50' - 800'	DV/DT*	2KHZ - 2.5KHZ
		> 800'	SINE WAVE **	> 4KHZ

**\*NOTE:** PM (Permanent Magnet) 4-Pole Motors with fundamental frequency up to 120hz will require DV/DT filter current derating.

**\*\*NOTE:** VFD Operating Frequencies greater than 75hz may need derating depending on filter manufacturer

### Input Current & Motor Overload Protection:

Motor input current should be set at the system's typical operating current when running at nameplate rated voltage and frequency (Hz).

Motor overload protection should be set to trip at 115% of the system's typical operating current.

Motor overload protection must trip equal to or faster than NEMA Class 10 motor overload curve requirements.

### Motor Maximum Load Limits:

- The system must never operate above the motor nameplate maximum amps.
- On 50 Hz motors, nameplate full load amps are maximum amps as these motors have a 1.0 service factor.

# Three-Phase Motors

## MOTOR APPLICATION

### Variable Frequency Drive Submersible Motor Requirements (Continued)

---

#### Motor Operating Hertz, Cooling Requirements, and Underload Settings:

- For three-phase induction submersible motors, the standard practice for large VFD installations is to limit the operation to 60 Hz max. Operating at greater than 60 Hz requires special system design considerations.
- The motor must never exceed maximum nameplate amps.
- The motor must never operate below 30 Hz. This is the minimum speed required to provide correct bearing lubrication.
- The motor's operating speed must always operate so the minimum water flow requirements of 0.5 ft/sec for 6" and 8" motors and 0.25 ft/sec for 4-inch motors is supplied.
- The motor underload protection trip point must be selected so that minimum flow requirements are always met.

#### VFD Frequency of Starts:

Keeping the starts per day within the recommended numbers shown in the frequency of starts section of the AIM manual provides the best system life. However, since in-rush current is typically reduced when used with a properly configured VFD, large 3-phase submersible motors can be started more frequently. In all cases a maximum of 200 starts per 24-hour period is recommended

#### Starting and Stopping Ramp Settings:

- The motor must reach or pass the 30 Hz operating speed within 1 second of the motor being energized. If this does not occur, the motor bearings will be damaged and the motor life reduced.
- The best stopping method is to turn power off followed by a natural coast to stop.
- A controlled stop from 30 Hz to 0 Hz is allowed if the time does not exceed 1 second.

#### Drive Carrier Frequency:

- The carrier frequency is set in the field. The drive normally has a selectable range between 2k and 12k Hz. The higher the carrier frequency setting, the more losses the drive will have which causes heat in the drive; the lower the carrier wave frequency setting, the rougher/poorer the shape of the power curve.
- The carrier frequency should typically be set within the range of 2k to 2.5k Hz for encapsulated submersible motors.

#### Application Function Setting:

If the VFD doesn't have a setting for submersible pump, use a centrifugal pump or propeller fan setting. Centrifugal pumps and fans have similar load characteristics.

#### Pressure Tank Sizing:

- VFD systems only need a small pressure tank to maintain constant pressure, although a larger tank may be used. For proper tank sizing, refer to the VFD manufacturer.
- For generic tank sizing, size the tank volume to be 10 to 20% of the pumps output rating at 60Hz. IE: a system capable of 100 GPM = 10-to-20-Gal tank by volume minimum.

#### NEMA MG1 Above Ground Motor Standard Comments:

- Franklin Electric encapsulated submersible motors are not declared inverter duty motors by NEMA MG1 standards. The reason is NEMA MG1 standard part 31 does not include a section covering encapsulated winding designs.
- Franklin submersible motors can be used with VFDs without problems or warranty concerns providing Franklin's Application, Installation, Maintenance (AIM) manual guidelines are followed. See Franklin's on-line AIM manual for the latest guidelines.

# All Motors

## INSTALLATION

### 4" Super Stainless — Dimensions

(Standard Water Well)

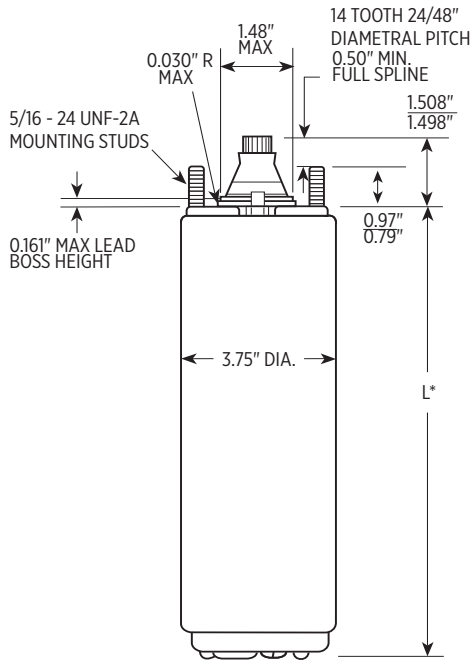

### 4" High Thrust — Dimensions

(Standard Water Well)

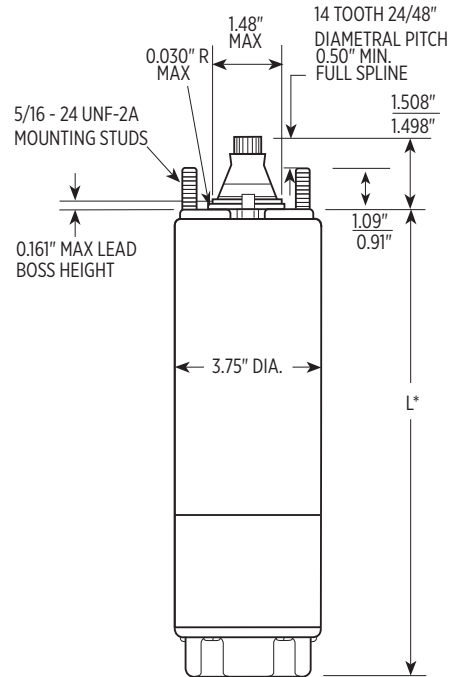

### 6" — Dimensions

(Standard Water Well)

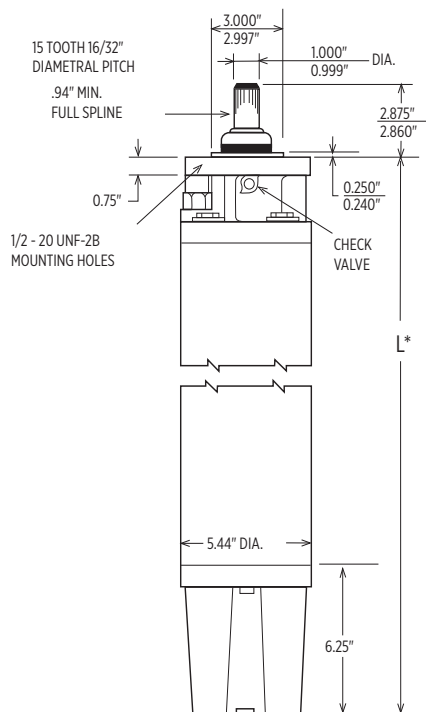

### 8" — Dimensions

(Standard Water Well)

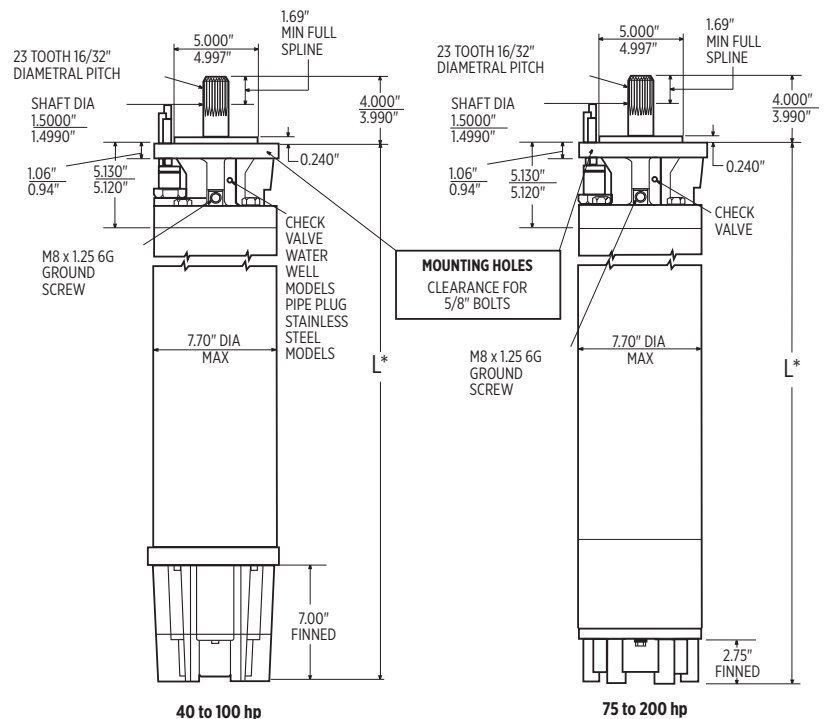

\* Motor lengths and shipping weights are available on Franklin Electric's web site ([www.franklin-electric.com](http://www.franklin-electric.com)) or by calling Franklin's Technical Service Hotline (800-348-2420).

# All Motors

## INSTALLATION

### Tightening Motor Lead Connector Jam Nut

**4" Motors with Jam Nut:**

15 to 20 ft-lb (20 to 27 Nm)

**4" Motors with 2 Screw Clamp Plate:**

35 to 45 in-lb (4.0 to 5.1 Nm)

**6" Motors:**

40 to 50 ft-lb (54 to 68 Nm)

**8" Motors with 1-3/16" to 1-5/8" Jam Nut:**

50 to 60 ft-lb (68 to 81 Nm)

**8" Motors with 4 Screw Clamp Plate:**

Apply increasing torque to the screws equally in a criss-cross pattern until 80 to 90 in-lb (9.0 to 10.2 Nm) is reached.

Jam nut tightening torques recommended for field assembly are shown. Rubber compression set within the first few hours after assembly may reduce the jam nut torque. This is a normal condition which does not indicate reduced seal effectiveness. Retightening is not required, but is permissible and recommended if original torque was questionable.

A motor lead assembly should not be reused. A new lead assembly should be used whenever one is removed from the motor, because rubber set and possible damage from removal may prevent proper resealing of the old lead.

**All motors returned for warranty consideration must have the lead returned with the motor.**

### Pump to Motor Coupling

Assemble coupling with non-toxic FDA approved waterproof grease such as Mobile FM222, Texaco CYGNUS2661, or approved equivalent. This prevents abrasives from entering the spline area and prolongs spline life.

### Pump to Motor Assembly

After assembling the motor to the pump, torque mounting fasteners to the following:

**4" Pump and Motor:** 10 lb-ft (14 Nm)

**6" Pump and Motor:** 50 lb-ft (68 Nm)

**8" Pump and Motor:** 120 lb-ft (163 Nm)

### Shaft Height and Free End Play

Table 43

MOTOR	NORMAL SHAFT HEIGHT		DIMENSION SHAFT HEIGHT		FREE END PLAY	
					MIN.	MAX.
4"	1 1/2"	38.1 mm	$\frac{1.508"}{1.498"}$	$\frac{38.30}{38.05}$ mm	0.010" 0.25 mm	0.045" 1.14 mm
6"	2 7/8"	73.0 mm	$\frac{2.875"}{2.860"}$	$\frac{73.02}{72.64}$ mm	0.030" 0.76 mm	0.050" 1.27 mm
8" TYPE 1	4"	101.6 mm	$\frac{4.000"}{3.990"}$	$\frac{101.60}{101.35}$ mm	0.008" 0.20 mm	0.032" 0.81 mm
8" TYPE 2.1	4"	101.6 mm	$\frac{4.000"}{3.990"}$	$\frac{101.60}{101.35}$ mm	0.030" 0.76 mm	0.080" 2.03 mm

If the height, measured from the pump-mounting surface of the motor, is low and/or end play exceeds the limit, the motor thrust bearing is possibly damaged, and should be replaced.

### Submersible Leads and Cables

A common question is why motor leads are smaller than specified in Franklin's cable charts.

The leads are considered a part of the motor and actually are a connection between the large supply wire and the motor winding. The motor leads are short and there is virtually no voltage drop across the lead.

In addition, the lead assemblies **operate under water**, while at least part of the supply cable must **operate in air**. Lead assemblies running under water operate cooler.

**CAUTION:** Lead assemblies on submersible motors are suitable only for use in water and may overheat and cause failure if operated in air.

# All Motors

## MOTOR MAINTENANCE

### System Troubleshooting

#### Motor Does Not Start

POSSIBLE CAUSE	CHECKING PROCEDURES	CORRECTIVE ACTION
A. No power or incorrect voltage	Check voltage at line terminals. The voltage must be $\pm 10\%$ of rated voltage.	Contact power company if voltage is incorrect.
B. Fuses blown or circuit breakers tripped	Check fuses for recommended size and check for loose, dirty or corroded connections in fuse receptacle. Check for tripped circuit breakers.	Replace with proper fuse or reset circuit breakers.
C. Defective pressure switch	Check voltage at contact points. Improper contact of switch points can cause voltage less than line voltage.	Replace pressure switch or clean points.
D. Control box malfunction	For detailed procedure, see pages 48-57.	Repair or replace.
E. Defective wiring	Check for loose or corroded connections or defective wiring.	Correct faulty wiring or connections.
F. Bound pump	Check for misalignment between pump and motor or a sand bound pump. Amp readings will be 3 to 6 times higher than normal until the overload trips.	Pull pump and correct problem. Run new installation until the water clears.
G. Defective cable or motor	For detailed procedure, see pages 46 & 47.	Repair or replace.

#### Motor Starts Too Often

A. Pressure switch	Check setting on pressure switch and examine for defects.	Reset limit or replace switch.
B. Check valve - stuck open	Damaged or defective check valve will not hold pressure.	Replace if defective.
C. Waterlogged tank	Check air charge.	Clean or replace.
D. Leak in system	Check system for leaks.	Replace damaged pipes or repair leaks.

# All Motors

## MOTOR MAINTENANCE

### System Troubleshooting

#### Motor Runs Continuously

POSSIBLE CAUSE	CHECKING PROCEDURES	CORRECTIVE ACTION
A. Pressure switch	Check switch for welded contacts. Check switch adjustments.	Clean contacts, replace switch, or adjust setting.
B. Low water level in well	Pump may exceed well capacity. Shut off pump, wait for well to recover. Check static and drawdown level from well head.	Throttle pump output or reset pump to lower level. Do not lower if sand may clog pump.
C. Leak in system	Check system for leaks.	Replace damaged pipes or repair leaks.
D. Worn pump	Symptoms of worn pump are similar to those of drop pipe leak or low water level in well. Reduce pressure switch setting, if pump shuts off worn parts may be the fault.	Pull pump and replace worn parts.
E. Loose coupling or broken motor shaft	Check for loose coupling or damaged shaft.	Replace worn or damaged parts.
F. Pump screen blocked	Check for clogged intake screen.	Clean screen and reset pump depth.
G. Check valve stuck closed	Check operation of check valve.	Replace if defective.
H. Control box malfunction	See pages 48-57 for single-phase.	Repair or replace.

#### Motor Runs But Overload Protector Trips

A. Incorrect voltage	Using voltmeter, check the line terminals. Voltage must be within $\pm 10\%$ of rated voltage.	Contact power company if voltage is incorrect.
B. Overheated protectors	Direct sunlight or other heat source can raise control box temperature causing protectors to trip. The box must not be hot to touch.	Shade box, provide ventilation or move box away from source.
C. Defective control box	For detailed procedures, see pages 48-57.	Repair or replace.
D. Defective motor or cable	For detailed procedures, see pages 45 & 46.	Repair or replace.
E. Worn pump or motor	Check running current, see tables 13, 22, 24, 25, & 27.	Replace pump and/or motor.

# All Motors

## MOTOR MAINTENANCE

**Table 46 Preliminary Tests - All Sizes Single- and Three-Phase**

TEST	PROCEDURE	WHAT IT MEANS
<b>Insulation Resistance (Fig. 10)</b>	<ol style="list-style-type: none"> <li>1. Open master breaker and disconnect all leads from control box or pressure switch (QD type control, remove lid) to avoid electric shock hazard and damage to the meter.</li> <li>2. Use a megohmmeter set to 1000 Volt (500 Volt minimum). If using an ohmmeter, set to R X 100k. Zero the meter.</li> <li>3. Connect one meter lead to any one of the motor leads and the other lead to the metal drop pipe. If the drop pipe is plastic, connect the meter lead to ground.</li> </ol>	<ol style="list-style-type: none"> <li>1. If the ohms value is normal (Table 47), the motor is not grounded and the cable insulation is not damaged.</li> <li>2. If the ohms value is below normal, either the windings are grounded or the cable insulation is damaged. Check the cable at the well seal as the insulation is sometimes damaged by being pinched.</li> </ol>
<b>Winding Resistance (Fig. 11)</b>	<ol style="list-style-type: none"> <li>1. Open master breaker and disconnect all leads from control box or pressure switch (QD type control, remove lid) to avoid electric shock hazard and damage to the meter.</li> <li>2. Use a multi-meter set to 20 ohms or an ohmmeter set to R X 1 for values under 10 ohms. Use next scale up for values over 10 ohms. Zero the meter.</li> <li>3. On 3-wire motors measure the resistance of yellow to black (main winding) and yellow to red (start winding).</li> </ol> <p>On 2-wire motors: measure the resistance from line-to-line.</p> <p>Three-phase motors: measure the resistance line-to-line for all three combinations.</p>	<ol style="list-style-type: none"> <li>1. If all ohms values are normal (Tables 13, 22, 24, 25, &amp; 27), the motor windings are neither shorted nor open, and the cable colors are correct</li> <li>2. If any one value is less than normal, the motor is shorted.</li> <li>3. If any one ohm value is greater than normal, the winding or the cable is open, or there is a poor cable joint or connection.</li> <li>4. If some ohms values are greater than normal and some less on single-phase motors, the leads are mixed. See page 48 to verify cable colors.</li> </ol>

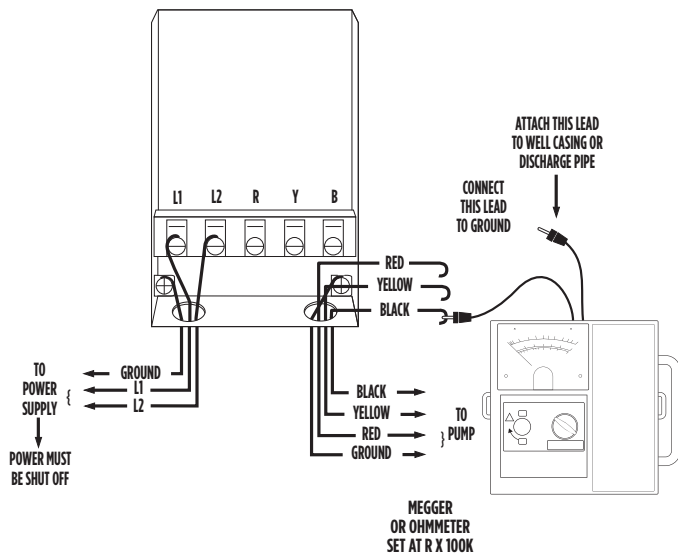

**FIG. 10**

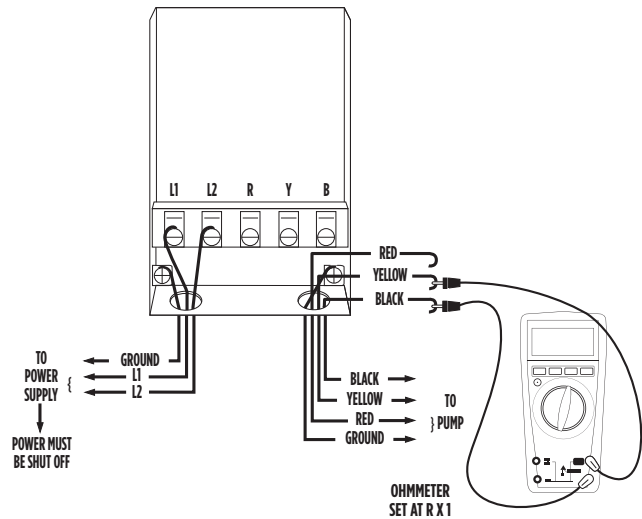

**FIG. 11**



# All Motors

## MOTOR MAINTENANCE

### Insulation Resistance Readings

**Table 47 Normal ohm and Megohm Values Between All Leads and Ground**

CONDITION OF MOTOR AND LEADS	MEGOHM VALUE	OHMS VALUE
A new motor (without drop cable)	200.0 (or more)	200,000,000 (or more)
A used motor which can be reinstalled in well	10.0 (or more)	10,000,000 (or more)
<b>MOTOR IN WELL. READINGS ARE FOR DROP CABLE PLUS MOTOR.</b>		
New motor	2.0 (or more)	2,000,000 (or more)
Motor in good condition	0.50 - 2.0	500,000 - 2,000,000
Insulation damage, locate and repair	Less than .50	Less than 500,000

Insulation resistance varies very little with rating. Motors of all hp, voltage, and phase rating have similar values of insulation resistance. The table above is based on readings taken with a megohm meter with a 500 VDC output. Readings may vary using a lower voltage ohmmeter; consult Franklin Electric if readings are in question.

### Resistance of Drop Cable (ohms)

The values below are for copper conductors. If aluminum conductor drop cable is used, the resistance will be higher. To determine the actual resistance of the aluminum drop cable, divide the ohm readings from this chart by 0.61. This chart shows total resistance of cable from control to motor and back.

### Winding Resistance Measuring

The winding resistance measured at the motor should fall within the values in Tables 13, 22, 24, 25, & 27. When measured through the drop cable, the resistance of the drop cable must be subtracted from the ohmmeter readings to get the winding resistance of the motor. See table below.

**Table 47A DC Resistance in ohms per 100 ft of Wire (Two conductors) @ 50 °F**

AWG OR MCM WIRE SIZE (COPPER)	14	12	10	8	6	4	3	2			
OHMS	0.544	0.338	0.214	0.135	0.082	0.052	0.041	0.032			
1	1/0	2/0	3/0	4/0	250	300	350	400	500	600	700
0.026	0.021	0.017	0.013	0.010	0.0088	0.0073	0.0063	0.0056	0.0044	0.0037	0.0032

# Single-Phase Motors & Controls

## MOTOR MAINTENANCE

### Identification Of Cables When Color Code Is Unknown (Single-Phase 3-Wire Units)

If the colors on the individual drop cables cannot be found with an ohmmeter, measure:

- Cable 1 to Cable 2
- Cable 2 to Cable 3
- Cable 3 to Cable 1

Find the highest resistance reading.

The lead not used in the highest reading is the yellow lead.

Use the yellow lead and each of the other two leads to get two readings:

- Highest is the red lead.
- Lowest is the black lead.

#### EXAMPLE:

##### The ohmmeter readings were:

- Cable 1 to Cable 2 - 6 ohms
- Cable 2 to Cable 3 - 2 ohms
- Cable 3 to Cable 1 - 4 ohms

The lead not used in the highest reading (6 ohms) was

Cable 3—Yellow

From the yellow lead, the highest reading (4 ohms) was

To Cable 1—Red

From the yellow lead, the lowest reading (2 ohms) was

To Cable 2—Black

### Single-Phase Control Boxes

#### Checking and Repairing Procedures (Power On)

**WARNING:** Power must be on for these tests. Do not touch any live parts.

#### A. VOLTAGE MEASUREMENTS

##### Step 1. Motor Off

1. Measure voltage at L1 and L2 of pressure switch or line contactor.
2. Voltage Reading: Should be  $\pm 10\%$  of motor rating.

##### Step 2. Motor Running

1. Measure voltage at load side of pressure switch or line contactor with pump running.
2. Voltage Reading: Should remain the same except for slight dip on starting. Excessive voltage drop can be caused by loose connections, bad contacts, ground faults, or inadequate power supply.
3. Relay chatter is caused by low voltage or ground faults.

#### B. CURRENT (AMP) MEASUREMENTS

1. Measure current on all motor leads.
2. Amp Reading: Current in red lead should momentarily be high, then drop within one second to values in Table 13. This verifies relay or solid state relay operation. Current in black and yellow leads should not exceed values in Table 13.
3. Relay or switch failures will cause red lead current to remain high and overload tripping.
4. Open run capacitor(s) will cause amps to be higher than normal in the black and yellow motor leads and lower than normal in the red motor lead.
5. A bound pump will cause locked rotor amps and overloading tripping.
6. Low amps may be caused by pump running at shut-off, worn pump, or stripped splines.
7. Failed start capacitor or open switch/relay are indicated if the red lead current is not momentarily high at starting.

**CAUTION:** The tests in this manual for components such as capacitors, relays, and QD switches should be regarded as indicative and not as conclusive. For example, a capacitor may test good (not open, not shorted) but may have lost some of its capacitance and may no longer be able to perform its function.

# Single-Phase Motors & Controls

## MOTOR MAINTENANCE

### Ohmmeter Tests

---

#### QD, Solid State Control Box (Power Off)

##### A. START CAPACITOR AND RUN CAPACITOR IF APPLICABLE (CRC)

1. Meter setting: R x 1,000.
2. Connections: Capacitor terminals.
3. Correct meter reading: Pointer should swing toward zero, then back to infinity.

##### B. Q.D. (BLUE) RELAY

###### Step 1. Triac Test

1. Meter setting: R x 1,000.
2. Connections: Cap and B terminal.
3. Correct meter reading: Infinity for all models.

###### Step 2. Coil Test

1. Meter setting: R x 1.
2. Connections: L1 and B.
3. Correct meter reading: Zero ohms for all models.

##### C. POTENTIAL (VOLTAGE) RELAY

###### Step 1. Coil Test

1. Meter setting: R x 1,000.
2. Connections: #2 & #5.
3. Correct meter readings:  
For 115 Volt Boxes:  
0.7-1.8 (700 to 1,800 ohms).  
For 230 Volt Boxes: 4.5-7.0 (4,500 to 7,000 ohms).

###### Step 2. Contact Test

1. Meter setting: R x 1.
2. Connections: #1 & #2.
3. Correct meter reading: Zero for all models.

### Ohmmeter Tests

---

#### Integral Horsepower Control Box (Power Off)

##### A. OVERLOADS (Push Reset Buttons to make sure contacts are closed.)

1. Meter setting: R x 1.
2. Connections: Overload terminals.
3. Correct meter reading: Less than 0.5 ohms.

##### B. CAPACITOR (Disconnect leads from one side of each capacitor before checking.)

1. Meter setting: R x 1,000.
2. Connections: Capacitor terminals.
3. Correct meter reading: Pointer should swing toward zero, then drift back to infinity, except for capacitors with resistors which will drift back to 15,000 ohms.

##### C. POTENTIAL (VOLTAGE) RELAY

###### Step 1. Coil Test

1. Meter setting: R x 1,000.
2. Connections: #2 & #5.
3. Correct meter readings: 4.5-7.0 (4,500 to 7,000 ohms) for all models.

###### Step 2. Contact Test

1. Meter setting: R x 1.
2. Connections: #1 & #2.
3. Correct meter reading: Zero ohms for all models.

##### D. CONTACTOR

###### Step 1. Coil

1. Meter setting: R x 100
2. Connections: Coil terminals
3. Correct meter reading: 1.8-14.0 (180 to 1,400 ohms)

###### Step 2. Contacts

1. Meter setting: R X 1
2. Connections: L1 & T1 or L2 & T2
3. Manually close contacts
4. Correct meter reading: Zero ohms

**CAUTION:** The tests in this manual for components such as capacitors, relays, and QD switches should be regarded as indicative and not as conclusive. For example, a capacitor may test good (not open, not shorted) but may have lost some of its capacitance and may no longer be able to perform its function.

# Single-Phase Motors & Controls

## MOTOR MAINTENANCE

**Table 50 QD Control Box Parts 60 Hz**

HP	VOLTS	CONTROL BOX MODEL NUMBER	QD (BLUE) RELAY	START CAPACITOR	MFD	VOLTS	RUN CAPACITOR	MFD	VOLTS
1/3	115	280 102 4915	223 415 905	275 464 125	159-191	110			
	230	280 103 4915	223 415 901	275 464 126	43-53	220			
1/2	115	280 104 4915	223 415 906	275 464 201	250-300	125			
	230	280 105 4915	223 415 902	275 464 105	59-71	220			
	230	282 405 5015 (CRC)	223 415 912	275 464 126	43-53	220	156 362 101	15	370
3/4	230	280 107 4915	223 415 903	275 464 118	86-103	220			
	230	282 407 5015 (CRC)	223 415 913	275 464 105	59-71	220	156 362 102	23	370
1	230	280 108 4915	223 415 904	275 464 113	105-126	220			
	230	282 408 5015 (CRC)	223 415 914	275 464 118	86-103	220	156 362 102	23	370

**Table 50A QD Capacitor Replacement Kits**

CAPACITOR NUMBER	KIT
275 464 105	305 207 905
275 464 113	305 207 913
275 464 118	305 207 918
275 464 125	305 207 925
275 464 126	305 207 926
275 464 201	305 207 951
156 362 101	305 203 907
156 362 102	305 203 908

**FOOTNOTES:**

- (1) Control boxes supplied with QD Relays are designed to operate on 230 Volt systems. For 208 Volt systems or where line voltage is between 200 volts and 210 volts use the next larger cable size, or use a boost transformer to raise the voltage.
- (2) Voltage relays kits for 115 Volts (305 102 901) and 230 Volts (305 102 902) will replace current, voltage or QD Relays, and solid state switches.

# Single-Phase Motors & Controls

## MOTOR MAINTENANCE

**Table 51 Integral Horsepower Control Box Parts 60 Hz**

MOTOR SIZE	MOTOR RATING HP	CONTROL BOX (1) MODEL NO.	CAPACITORS				OVERLOAD (2) PART NO.	RELAY (3) PART NO.	CONTACTOR (2) PART NO.
			PART NO. (2)	MFD.	VOLTS	QTY.			
4"	1 - 1.5 STANDARD	282 300 8110 (See Note 5)	275 464 113 S 155 328 102 R	105-126 10	220 370	1 1	275 411 107	155 031 102	
		282 300 8110 (See Note 5)	275 464 137 S 155 328 101 R	105-126 15	220 370	1 1	275 411 114 S 275 411 113 M	155 031 102	
		282 300 8610	275 464 113 S 155 328 101 R	105-126 15	220 370	1 1	None (See Note 4)	155 031 102	
4"	2 STANDARD	282 301 8110	275 464 137 S 155 328 103 R	105-126 20	220 370	1 1	275 411 117 S 275 411 113 M	155 031 102	
4"	2 DELUXE	282 301 8310	275 464 137 S 155 328 103 R	105-126 20	220 370	1 1	275 411 117 S 275 411 113 M	155 031 102	155 325 102 L
4"	3 STANDARD	282 302 8110	275 463 123 S 155 327 109 R	208-250 45	220 370	1 1	275 411 118 S 275 411 115 M	155 031 102	
4"	3 DELUXE	282 302 8310	275 463 123 S 155 327 109 R	208-250 45	220 370	1 1	275 411 118 S 275 411 115 M	155 031 102	155 325 102 L
4" & 6"	5 STANDARD	282 113 8110	275 468 118 S 155 327 114 R	216-259 40	330 370	1 2	275 411 119 S 275 406 102 M	155 031 601	
4" & 6"	5 DELUXE	282 113 9310	275 468 118 S 155 327 114 R	216-259 40	330 370	1 2	275 411 119 S 275 406 102 M	155 031 601	155 326 101 L
6"	7.5 STANDARD	282 201 9210	275 468 119 S 275 468 117 S 155 327 109 R	270-324 130-154 45	330 330 370	1 1 1	275 411 102 S 275 406 122 M	155 031 601	
			282 201 9310	275 468 119 S 275 468 117 S 155 327 109 R	270-324 130-154 45	330 330 370	1 1 1	275 411 102 S 275 406 121 M	155 031 601
6"	10 STANDARD	282 202 9210	275 468 119 S 275 468 120 S 155 327 102 R	270-324 350-420 35	330 330 370	1 1 2	275 406 103 S 155 409 101 M	155 031 601	
			282 202 9230	275 468 119 S 155 327 102 R	270-324 35	330 370	2 2	275 406 103 S 155 409 101 M	155 031 601
6"	10 DELUXE	282 202 9310	275 468 119 S 275 468 120 S 155 327 102 R	270-324 350-420 35	330 330 370	1 1 2	275 406 103 S 155 409 101 M	155 031 601	155 326 102 L
			282 202 9330	275 468 119 S 155 327 102 R	270-324 35	330 370	2 2	275 406 103 S 155 409 101 M	155 031 601
6"	15 DELUXE	282 203 9310	275 468 120 S 155 327 109 R	350-420 45	330 370	2 3	275 406 103 S 155 409 102 M	155 031 601	155 429 101 L
			282 203 9330	275 468 119 S 155 327 109 R	270-324 45	330 370	2 3	275 406 103 S 155 409 102 M	155 031 601
6"	15 X-LARGE	282 203 9621	275 468 119 S 155 327 109 R	270-324 45	330 370	2 3	275 406 103 S 155 409 102 M	155 031 601 2 required	155 429 101 L

### FOOTNOTES:

- (1) Surge arrestors 150 814 902 are suitable for all control boxes.
- (2) S = Start, M = Main, L = Line, R = Run  
Deluxe = Control box with line contactor.
- (3) For 208 Volt systems or where line voltage is between 200 volts and 210 volts, a low voltage relay is required. On 3 hp and smaller control boxes use relay part 155 031 103 in place of 155 031 102 and use the next larger cable size than specified in the 230 Volt table. On 5 hp and larger use relay 155 031 602 in place of 155 031 601 and next larger wire. Boost transformers per page 15 are an alternative to special relays and cable.
- (4) Control box model 282 300 8610 is designed for use with motors having internal overload protectors. If used with a 1.5 hp motor manufactured prior to date code 06H18, Overload/ Capacitor Kit 305 388 901 is required.
- (5) Control box model 282 300 8110 with date code 11C19 (March 2011) and newer contain 15 MFD run capacitor and both start and run overloads. This box is designed for use with any Franklin 1.5 hp motor.

# Single-Phase Motors & Controls

## MOTOR MAINTENANCE

**Table 52 Integral hp Capacitor Replacement Kits**

CAPACITOR NUMBER	KIT
275 463 120	305 206 920
275 463 122	305 206 922
275 463 123	305 206 923
275 464 113	305 207 913
275 464 137	305 207 937
275 468 117	305 208 917
275 468 118	305 208 918
275 468 119	305 208 919
275 468 120	305 208 920
155 327 101	305 203 901
155 327 102	305 203 902
155 327 109	305 203 909
155 327 114	305 203 914
155 328 101	305 204 901
155 328 102	305 204 902
155 328 103	305 204 903

**Table 52A Integral hp Overload Replacement Kits**

OVERLOAD NUMBER	KIT
275 406 102	305 214 902
275 406 103	305 214 903
275 406 121	305 214 921
275 406 122	305 214 922
275 411 102	305 215 902
275 411 107	305 215 907
275 411 108	305 215 908
275 411 113	305 215 913
275 411 114	305 215 914
275 411 115	305 215 915
275 411 117	305 215 917
275 411 118	305 215 918
275 411 119	305 215 919

**Table 52B Integral hp Voltage Relay Replacement Kits**

RELAY NUMBER	DESCRIPTION	KIT
155 031 102	230V STANDARD DUTY	305 213 902
155 031 103	208V STANDARD DUTY	305 213 903
155 031 601	230V HEAVY DUTY	305 213 961
155 031 602	208V HEAVY DUTY	305 213 962

**Table 52C Integral hp Contactor Replacement Kits**

CONTACTOR	KIT
155 325 102	305 226 902
155 326 101	305 347 903
155 326 102	305 347 902
155 429 101	305 347 901

**FOOTNOTES:**

- (1) The following kit number changes were made for number consistency purposes only. Parts in the kit did not change.  
 305 206 922 was 305 206 912  
 305 206 923 was 305 206 911  
 305 213 962 was 305 213 904  
 305 226 902 was 305 226 901

# Single-Phase Motors & Controls

## MOTOR MAINTENANCE

### Control Box Wiring Diagrams

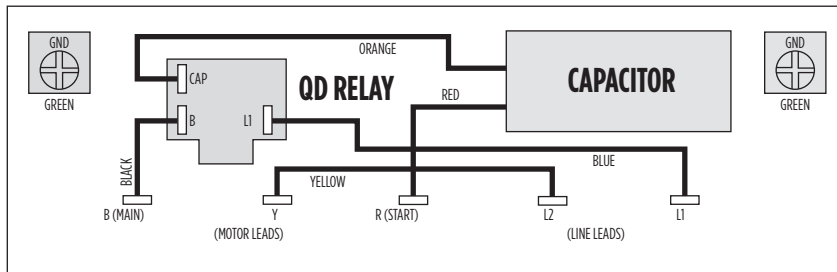

**1/3 - 1 hp QD RELAY**  
280 10\_4915  
Sixth digit depends on hp

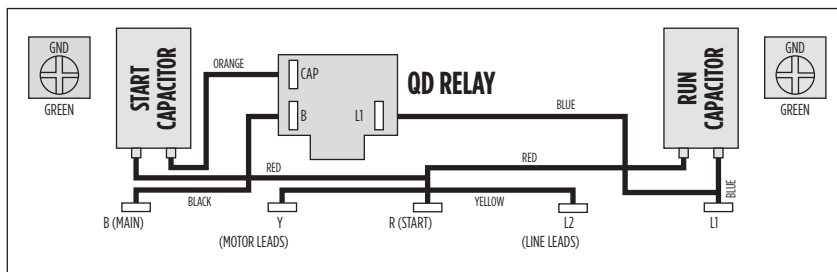

**1/2 - 1 hp CRC QD RELAY**  
282 40\_5015  
Sixth digit depends on hp

# Single-Phase Motors & Controls

## MOTOR MAINTENANCE

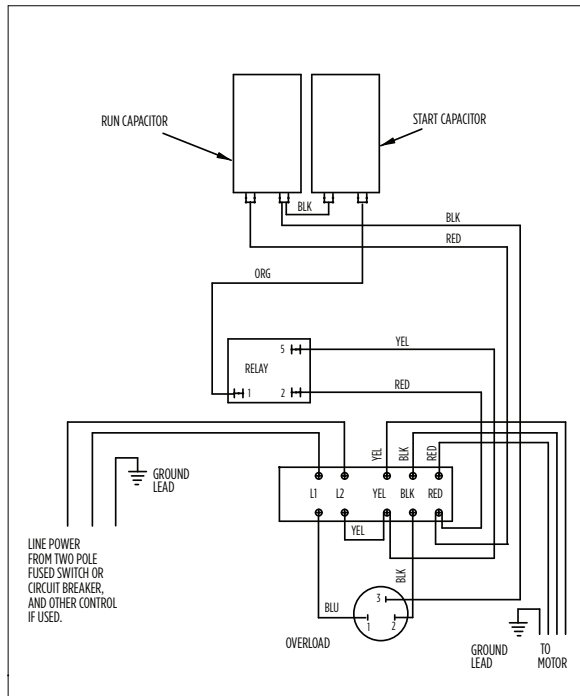

**1 - 1.5 hp**  
 282 300 8110  
 (Date Codes 11C19 & Older)

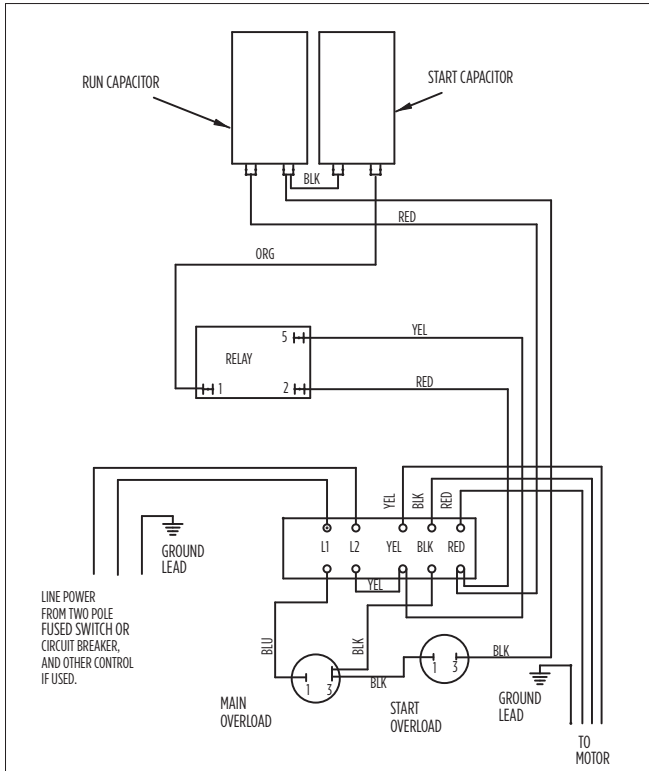

**1 - 1.5 hp**  
 282 300 8110  
 (Date Codes 11C19 & Newer)

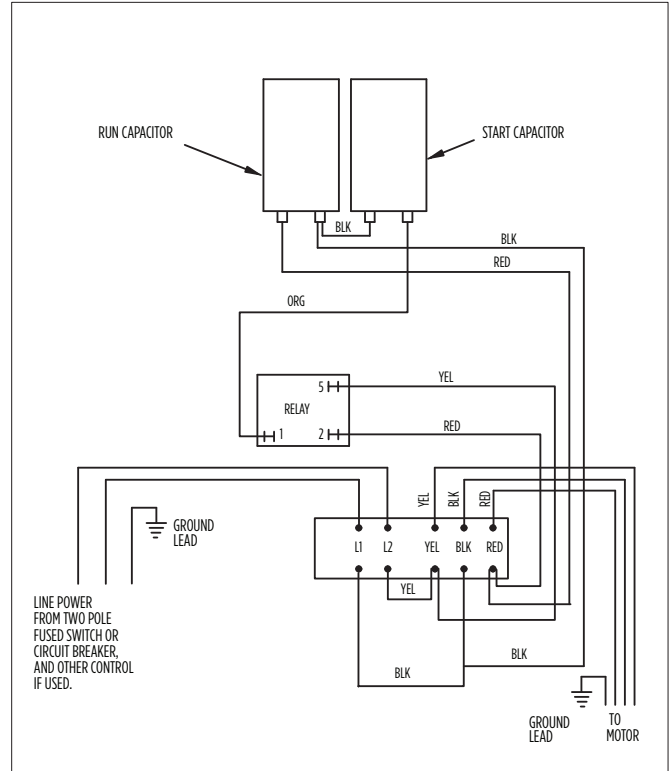

**1 - 1.5 hp**  
 282 300 8610



# Single-Phase Motors & Controls

## MOTOR MAINTENANCE

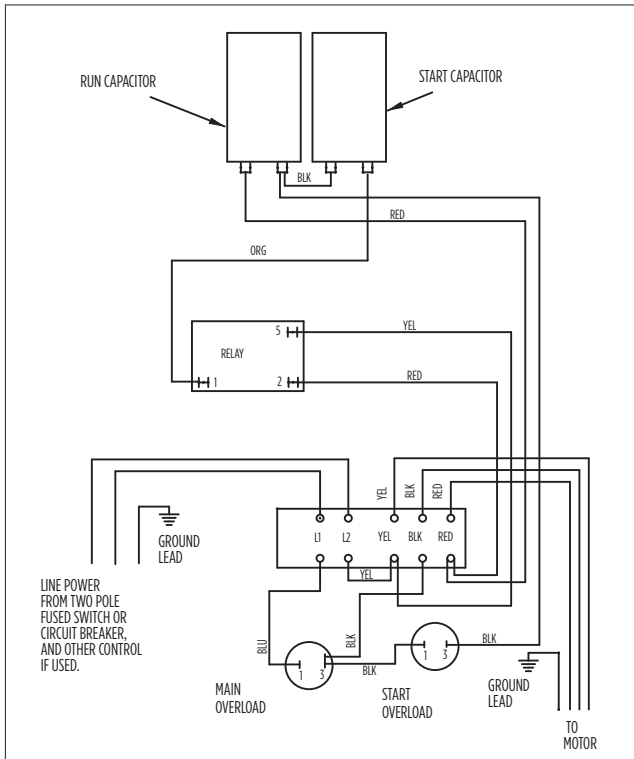

**2 hp STANDARD**  
282 301 8110

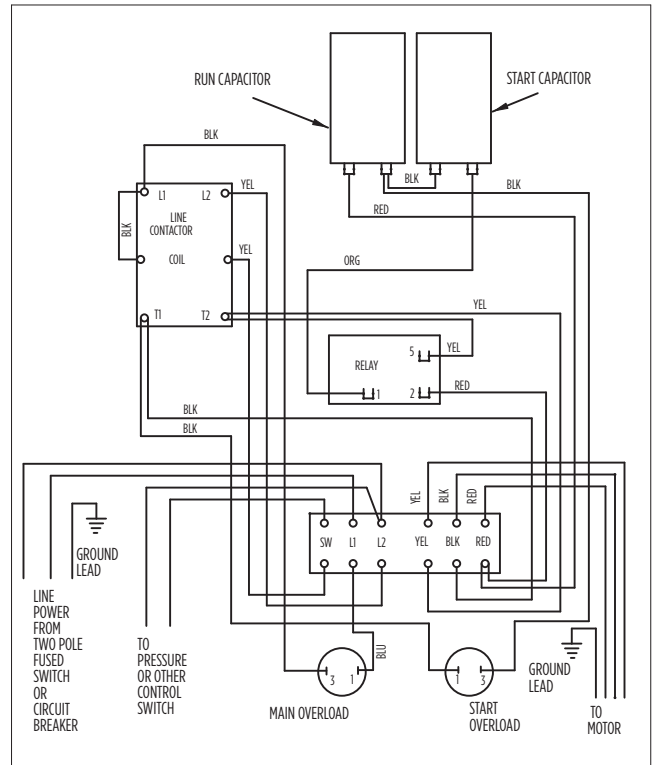

**2 hp DELUXE**  
282 301 8310

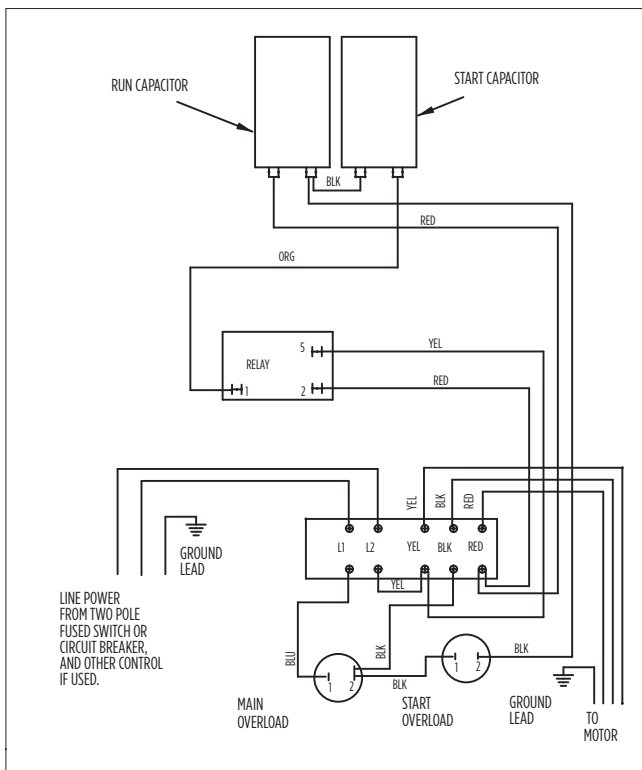

**3 hp STANDARD**  
282 302 8110

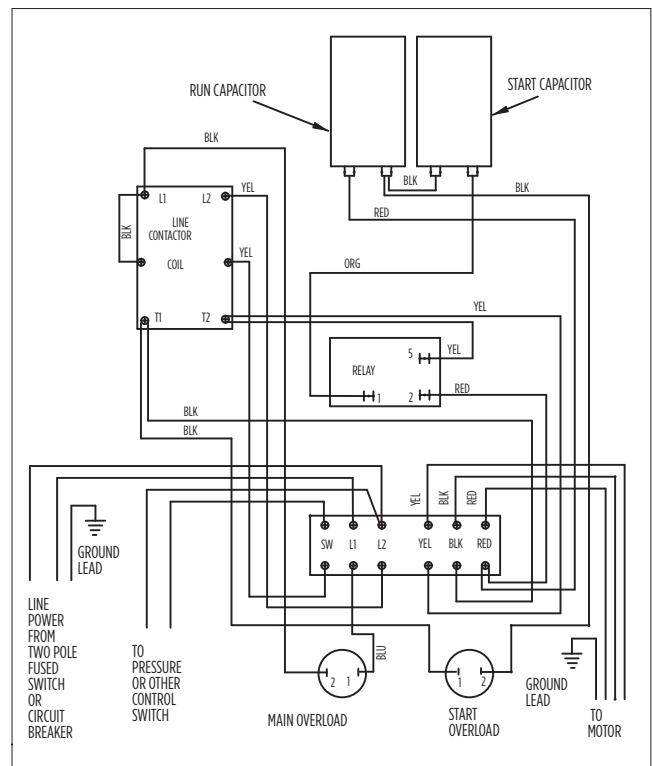

**3 hp DELUXE**  
282 302 8310

# Single-Phase Motors & Controls

## MOTOR MAINTENANCE

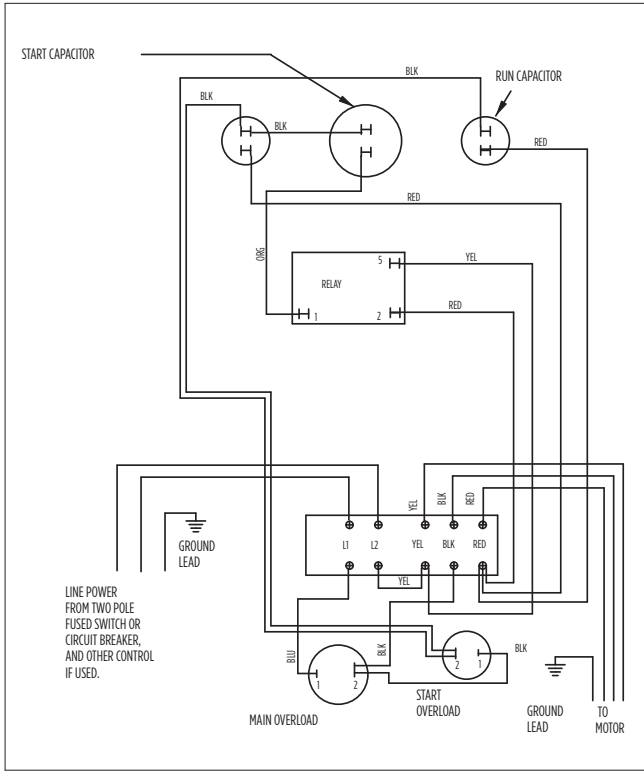

**5 hp STANDARD**  
282 113 8110

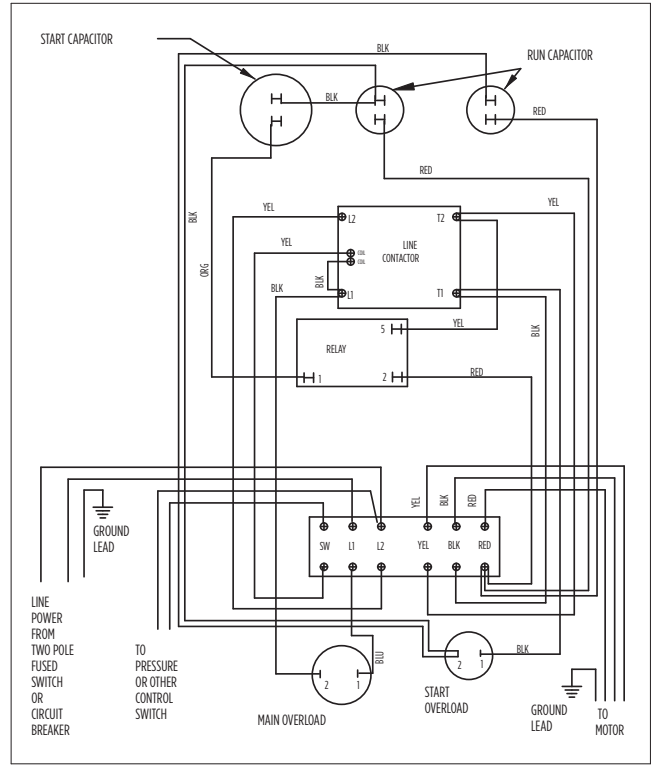

**5 hp DELUXE**  
282 113 8310 or 282 113 9310

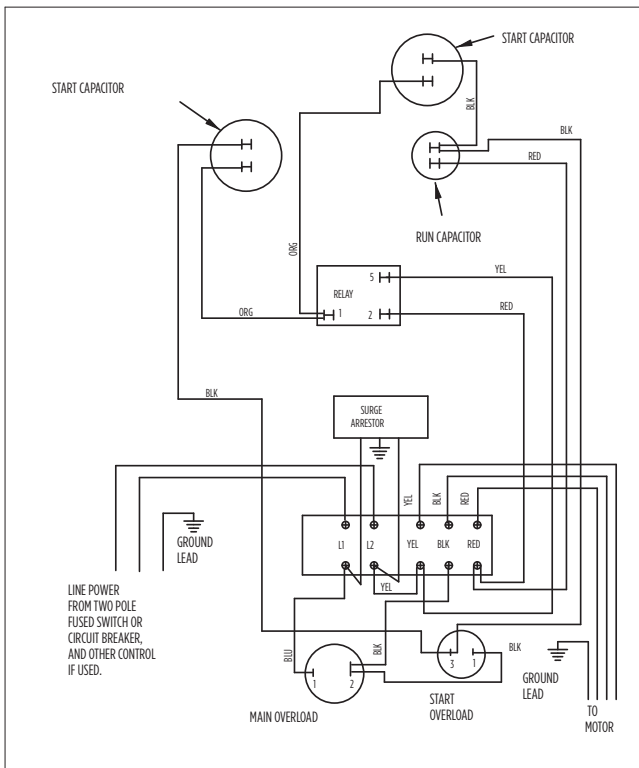

**7.5 hp STANDARD**  
282 201 9210

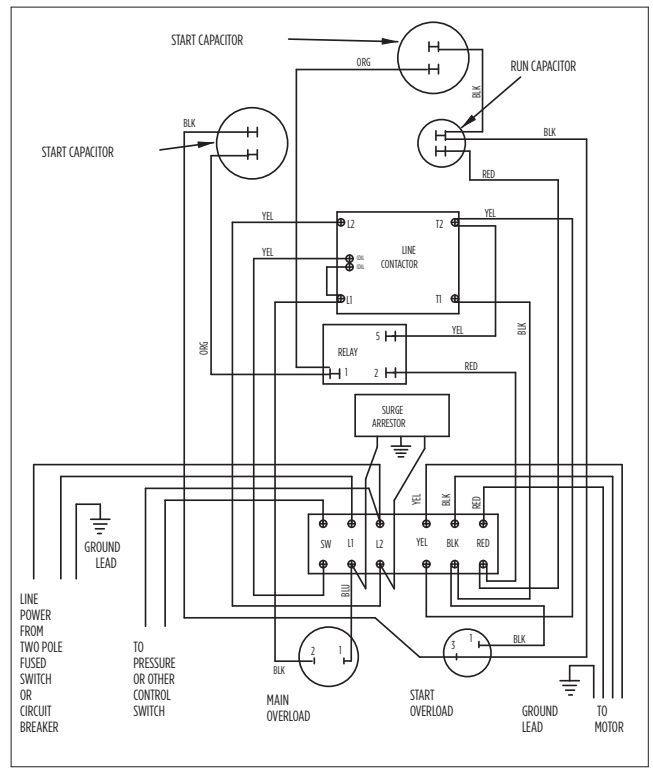

**7.5 hp DELUXE**  
282 201 9310



# Electronic Products

## ELECTRONIC APPLICATION

### SubDrives & MonoDrives

The Franklin Electric SubDrive/MonoDrive controller is a variable-speed drive that delivers water at a constant pressure. MonoDrive and MonoDriveXT are designed to convert a conventional 3-wire 1/2 hp to 2 hp pump system to a variable speed constant pressure system by simply replacing the 3-wire control box and pressure switch. The SubDrive 3-phase models are designed for three-phase motors to provide constant pressure with three-phase performance using single-phase input power. The SubDrive2W is designed to convert a conventional 2-wire 1/2 hp, 3/4 hp, and 1 hp pump system to a variable speed constant pressure system by simply replacing the pressure switch.

#### Applications

- Residential homes
- Schools
- Restaurants
- Car washes
- Farms
- Landscape irrigation systems

#### Protects Against

- Surge protection
- Overheated controller
- Locked pump
- Short circuits
- Undervoltage
- Open circuit
- Underload
- Broken pipe detection (NEMA 3R only excluding 2W)
- User-configurable underload off time (NEMA 3R only excluding 2W)



**WARNING:** Serious or fatal electrical shock may result from failure to connect the motor, SubDrive/MonoDrive Controller, metal plumbing, and all other metal near the motor or cable to the power supply ground terminal using wire no smaller than motor cable wires. To reduce the risk of electrical shock, disconnect power before working on or around the water system. Capacitors inside the SubDrive/MonoDrive Controller can still hold a lethal voltage even after power has been removed. Allow 10 minutes for dangerous internal voltage to discharge. Do not use motor in swimming areas.

### Generator Sizing for SubDrive/MonoDrive

Basic generator sizing for the Franklin Electric SubDrive/MonoDrive system is 1.5 times maximum input watts consumed by the drive, rounded up to the next normal sized generator.

Recommended minimum generator sizes:

#### MonoDrive

- 1/2 hp (0.37 kW) = 2000 watts (2 kW)
- 3/4 hp (0.55 kW) = 3000 watts (3 kW)
- 1 hp (0.75 kW) = 3500 watts (3.5 kW)

#### MonoDriveXT

- 1.5 hp (1.1kW) = 4000 watts (4 kW)
- 2 hp (1.5 kW) = 5000 watts (5 kW)

**SubDrive15** = 3500 watts (3.5 kW)

**SubDrive20** = 5700 watts (6 kW)

**SubDrive30** = 7000 watts (7 kW)

**SubDrive2W** = 6000 watts (6 kW)

**SubDrive75** = 3500 watts (3.5 kW)

**SubDrive100** = 5700 watts (6 kW)

**SubDrive150** = 7000 watts (7 kW)

**SubDrive300** = 11000 watts (11 kW)

**SubDrive2W** = 6000 watts (6 kW)

**Note:** Not to be used on a Ground Fault Circuit Interruptor (GFCI). If using an externally regulated generator, verify that the voltage and Hertz are appropriate to supply the drive.

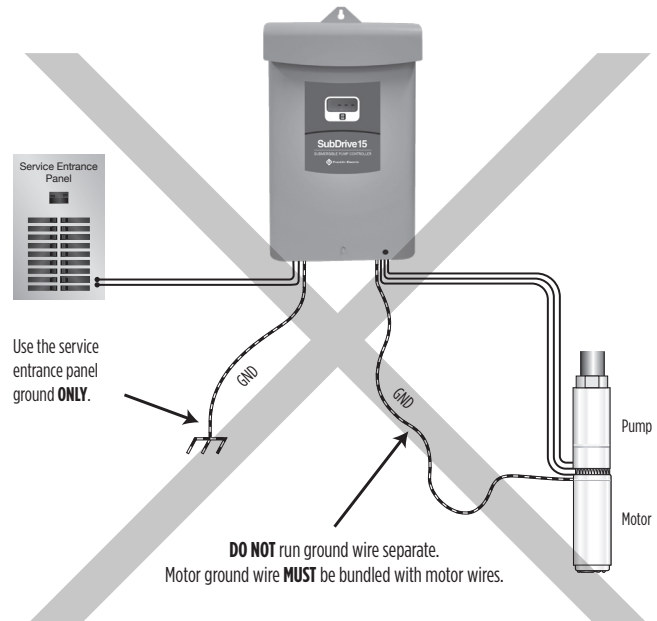

# Electronic Products

## ELECTRONIC APPLICATION

### Fuse/Circuit Breaker and Wire Sizing

The Listed fuse/Listed circuit breaker size and maximum allowable wire lengths for connection to the SubDrive/MonoDrive are given in the following tables:

**Table 59 Circuit Breaker Sizing and Maximum Input Cable Lengths (in Feet)**

Based on a 3% voltage drop

CONTROLLER MODEL	LISTED FUSE / LISTED CIRCUIT BREAKER AMPS	NOMINAL INPUT VOLTAGE	AWG COPPER WIRE SIZES, 167° F (75° C) INSULATION UNLESS OTHERWISE NOTED										
			14	12	10	8	6	4	3	2	1	1/0	2/0
MonoDrive	15	208	80	125	205	315	500	790	980	1290	1635	-	-
		230	95	150	250	385	615	970	1200	1580	2000	-	-
SubDrive15 / SubDrive75	15	208	70	110	185	280	450	710	880	1160	1465	-	-
		230	85	135	225	345	550	865	1075	1415	1795	-	-
SubDrive2W	20	230	-	125	205	315	505	795	985	1295	1645	-	-
MonoDriveXT	20	208	-	85	140	220	345	550	680	895	1135	-	-
		230	-	105	175	265	425	670	835	1095	1390	-	-
SubDrive20 / SubDrive100	25	208	-	-	115	180	285	450	555	730	925	-	-
	20	230	-	85	140	220	345	550	680	895	1130	-	-
SubDrive30 / SubDrive150	30	208	-	-	95	145	235	370	460	605	765	-	-
	25	230	-	-	115	180	285	455	560	740	935	-	-
SubDrive300	40	208	-	-	-	-	150	235	295	385	490	610	735
	40	230	-	-	-	115	185	290	360	470	600	745	895

XXXX Highlighted numbers denote wire with 194 °F (90 °C) insulation only

**Table 59A Maximum Motor Cable Length (in Feet)**

CONTROLLER MODEL	FRANKLIN ELECTRIC MOTOR MODEL	HP	AWG COPPER WIRE SIZES, 140° F (60 °C) INSULATION					
			14	12	10	8	6	4
SubDrive15 / SubDrive75	234 514 xxxx	1.5 (1.1 kW)	420	670	1060	-	-	-
SubDrive20 / SubDrive100	234 315 xxxx	2.0 (1.5 kW)	320	510	810	1000	-	-
SubDrive30 / SubDrive150	234 316 xxxx	3.0 (2.2 kW)	240	390	620	990	-	-
SubDrive300	234 317 xxxx	5.0 (3.7 kW)	-	230	370	590	920	-
SubDrive2W	244 505 xxxx	1/2 (.37 kW)	400	650	1000	-	-	-
	244 507 xxxx	3/4 (.55 kW)	300	480	760	1000	-	-
	244 508 xxxx	1.0 (.75 kW)	250	400	630	990	-	-
MonoDrive	214 505 xxxx	1/2 (.37 kW)	400	650	1020	-	-	-
	214 507 xxxx	3/4 (.55 kW)	300	480	760	1000	-	-
	214 508 xxxx	1.0 (.75 kW)	250	400	630	990	-	-
MonoDriveXT	214 508 xxxx	1.0 (0.75kW)	250	400	630	990	-	-
	224 300 xxxx	1.5 (1.1 kW)	190	310	480	770	1000	-
	224 301 xxxx	2.0 (1.5kW)	150	250	390	620	970	-

A 10-foot (3.05 m) section of cable is provided with the SubDrive/MonoDrive to connect the pressure sensor.

**Notes:**

- 1 ft = 0.305 m.
- Maximum allowable wire lengths are measured between the controller and motor.
- Aluminum wires should not be used with the SubDrive/MonoDrive.
- All wiring to comply with the National Electrical Code and/or local codes.
- MonoDrive minimum breaker amps may be lower than AIM manual specifications for the motors listed due to the soft-starting characteristic of the MonoDrive controller.
- SubDrive minimum breaker amps may appear to exceed AIM manual specifications for the motors listed because SubDrive controllers are supplied from a single-phase service rather than three-phase. Amps (SFA). Motor overtemperature sensing is not provided by the drive.
- Motor Overload Protection: The drive electronics provide motor overload protection by preventing motor current from exceeding the maximum Service Factor Amps (SFA). Motor overtemperature sensing is not provided by the drive.

# Electronic Products

## ELECTRONIC APPLICATION

### Pressure Tank

The SubDrive/MonoDrive needs only a small pressure tank to maintain constant pressure. (See Table 60 for recommended tank size.) For pumps rated 12 gpm (45.4 lpm) or more, a slightly larger tank is recommended for optimum pressure regulation. The SubDrive/MonoDrive can also use an existing tank with a much larger capacity.

**Table 60 Minimum Pressure Tank Size (Total Capacity)**

PUMP FLOW RATING	CONTROLLER MODEL	MINIMUM TANK SIZE
Less than 12 gpm (45.4 lpm)	SubDrive15, SubDrive75 or MonoDrive	2 gallons (7.6 liters)
	SubDrive20 or SubDrive100	4 gallons (15.1 liters)
	SubDrive30, SubDrive150 or MonoDriveXT	4 gallons (15.1 liters)
	SubDrive300	8 gallons (30.3 liters)
12 gpm and higher (45.4 lpm)	SubDrive15, SubDrive75 or MonoDrive	4 gallons (15.1 liters)
	SubDrive20 or SubDrive100	8 gallons (30.3 liters)
	SubDrive30, SubDrive150 or MonoDriveXT	8 gallons (30.3 liters)
	SubDrive300	20 gallons (75.7 liters)
All flows	SubDrive2W	20 gallons (75.7 liters)

**Table 60A Pressure Tank Pre-charge (PSI)**

SYSTEM PRESSURE (AT PRESSURE SENSOR)	PRESSURE TANK SETTING (±2 PSI)
25	18
30	21
35	25
40	28
45	32
50 (Factory Set)	35
55	39
60	42
65	46
70	49
75	53
80	56

1 PSI = 0.068 bar

**Note:** Check tank pre-charge regularly to maintain optimum pressure regulation.

**Table 60B Minimum Pipe Diameter**

MAXIMUM VELOCITY 8 FT/SEC. (2.4 M/S)	
MIN PIPE DIA	MAX GPM (LPM)
1/2"	4.9 (18.5)
3/4"	11.0 (41.6)
1"	19.6 (74.2)
1-1/4"	30.6 (115.8)
1-1/2"	44.1 (166.9)
2"	78.3 (296.4)
2-1/2"	176.3 (667.4)

# Electronic Products

## ELECTRONIC MAINTENANCE

### Pumptec-Plus

Pumptec-Plus is a pump/motor protection device designed to work on any 230 V single-phase induction motor (PSC, CSCR, CSIR, and split phase) ranging in size from 1/2 to 5hp. Pumptec-Plus uses a micro-computer to continuously monitor motor power and line voltage to provide protection against dry well, water logged tank, high and low voltage and mud or sand clogging.

### Pumptec-Plus – Troubleshooting During Installation

SYMPTOM	POSSIBLE CAUSE	SOLUTION
<b>Unit Appears Dead (No Lights)</b>	No Power to Unit	Check wiring. Power supply voltage should be applied to L1 and L2 terminals of the Pumptec-Plus. In some installations the pressure switch or other control devices is wired to the input of the Pumptec-Plus. Make sure this switch is closed.
<b>Flashing Yellow Light</b>	Unit Needs to Be Calibrated	Pumptec-Plus is calibrated at the factory so that it will overload on most pump systems when the unit is first installed. This overload condition is a reminder that the Pumptec-Plus unit requires calibration before use. See step 7 of the installation instructions.
	Miscalibrated	Pumptec-Plus should be calibrated on a full recovery well with the maximum water flow. Flow restrictors are not recommended.
<b>Flashing Yellow Light During Calibration</b>	2-Wire Motor	Step C of the calibration instructions indicate that a flashing green light condition will occur 2 to 3 seconds after taking the SNAPSHOT of the motor load. On some two-wire motors the yellow light will flash instead of the green light. Press and release the reset button. The green should start flashing.
<b>Flashing Red and Yellow Lights</b>	Power Interruption	During the installation of Pumptec-Plus power may be switched on and off several times. If power is cycled more than four times within a minute Pumptec-Plus will trip on rapid cycle. Press and release the reset button to restart the unit.
	Float Switch	A bobbing float switch may cause the unit to detect a rapid cycle condition on any motor or an overload condition on two-wire motors. Try to reduce water splashing or use a different switch.
<b>Flashing Red Light</b>	High Line Voltage	The line voltage is over 253 volts. Check line voltage. Report high line voltage to the power company.
	Unloaded Generator	If you are using a generator the line voltage may become too high when the generator unloads. Pumptec-Plus will not allow the motor to turn on again until the line voltage returns to normal. Overvoltage trips will also occur if line frequency drops too far below 60 Hz.
<b>Solid Red Light</b>	Low Line Voltage	The line voltage is below 207 volts. Check line voltage.
	Loose Connections	Check for loose connections which may cause voltage drops.
	Loaded Generator	If you are using a generator the line voltage may become too low when the generator loads. Pumptec-Plus will trip on undervoltage if the generator voltage drops below 207 volts for more than 2.5 seconds. Undervoltage trips will also occur if the line frequency rises too far above 60 Hz.

# Electronic Products

## ELECTRONIC MAINTENANCE

### Pumptec-Plus and Pumptec with 3-lights

#### Pumptec-Plus and Pumptec with 3 lights - Troubleshooting After Installation

SYMPTOM	POSSIBLE CAUSE	SOLUTION
<b>Solid Yellow Light</b>	Dry Well	Wait for the automatic restart timer to time out. During the time out period, the well should recover and fill with water. If the automatic reset timer of the Pumptec-Plus is set to the manual position, push the reset button to reactivate the unit. If the reset timer is set to manual in the Pumptec, turn off power for 5 seconds to reset the unit.
	Blocked Intake	Clear or replace pump intake screen.
	Blocked Discharge	Remove blockage in plumbing.
	Check Valve Stuck	Replace check valve.
	Broken Shaft	Replace broken parts.
	Severe Rapid Cycling	Machine gun rapid cycling can cause an underload condition. See flashing red and yellow lights section below.
	Worn Pump	Replace worn pump parts and recalibrate.
<b>Flashing Yellow Light</b>	Stalled Motor	Repair or replace motor. Pump may be sand or mud locked.
	Float Switch	A bobbing float switch can cause two-wire motors to stall. Arrange plumbing to avoid splashing water. Replace float switch.
	Ground Fault	Check insulation resistance on motor and control box cable.
<b>Solid Red Light</b>	Low Line Voltage	The line voltage is below 207 volts. Pumptec and Pumptec-Plus will try to restart the motor approximately every two minutes until the line voltage is normal.
	Loose Connections	Check for excessive voltage drops in the system electrical connections (i.e. circuit breakers, fuse clips, pressure switch, and Pumptec-Plus L1 and L2 terminals). Repair connections.
<b>Flashing Red Light</b>	High Line Voltage	The line voltage is over 253 volts. Check line voltage. Report high line voltage to the power company.
<b>Flashing Red and Yellow Lights</b>	Rapid Cycle	The most common cause for the rapid cycle condition is a waterlogged tank. Check for a ruptured bladder in the water tank. Check the air volume control or sniffer valve for proper operation. Check setting on the pressure switch and examine for defects.
	Leaky Well System	Replace damaged pipes or repair leaks.
	Stuck Check Valve	Failed valve will not hold pressure. Replace valve.
	Float Switch	A bobbing float switch may cause the unit to detect a rapid cycle condition on any motor or an overload condition on 2-wire motors. To reset a Pumptec, remove power for 5 seconds. To reset a Pumptec-Plus, press and release the reset button. To eliminate float switch bounce, try to reduce water splash or use a different switch.



# Electronic Products

## ELECTRONIC MAINTENANCE

### QD Pumptec and Pumptec with 2-lights or no lights

QD Pumptec and the old 2-light version of Pumptec are load sensing devices that monitor the load on submersible pumps/motors. If the load drops below a preset level for a minimum of 4 seconds the QD Pumptec or the Pumptec will shut off the motor.

The QD Pumptec is designed and calibrated expressly for use on Franklin Electric 230 V 3-wire motors (1/3 to 1 hp.) The QD Pumptec must be installed in QD relay boxes.

The Pumptec is designed for use on Franklin Electric 2- and 3-wire motors (1/3 to 1.5 hp) 115 and 230 V. The Pumptec is not designed for jet pumps.

### QD Pumptec & Pumptec – Troubleshooting

SYMPTOM	CHECKS OR SOLUTION
<p><b>If the QD Pumptec or Pumptec trips in about 4 seconds with some water delivery.</b></p>	<ul style="list-style-type: none"> <li>A. Is the voltage less than 90% of nameplate rating?</li> <li>B. Are the pump and motor correctly matched?</li> <li>C. Is the <b>QD Pumptec</b> or <b>Pumptec</b> wired correctly? For the <b>Pumptec</b> check the wiring diagram and pay special attention to the positioning of the power lead (230 V or 115 V). Pre-2006 Pumptec used different wiring guidelines.</li> <li>D. For <b>QD Pumptec</b> is your system 230 V 60 Hz or 220 V 50 Hz?</li> </ul>
<p><b>If the QD Pumptec or Pumptec trips in about 4 seconds with no water delivery.</b></p>	<ul style="list-style-type: none"> <li>A. The pump may be airlocked. If there is a check valve on top of the pump, put another section of pipe between the pump and the check valve.</li> <li>B. The pump may be out of water.</li> <li>C. Check the valve settings. The pump may be dead-heading.</li> <li>D. Pump or motor shaft may be broken.</li> <li>E. Motor overload may be tripped. Check the motor current (amperage).</li> </ul>
<p><b>If the QD Pumptec or Pumptec will not timeout and reset.</b></p>	<ul style="list-style-type: none"> <li>A. Check switch position on side of circuit board on <b>Pumptec</b>. <b>QD Pumptec</b> check timer position on top/front of unit. Make sure the switch is not between settings.</li> <li>B. If the reset time switch is set to manual reset (position 0), <b>QD Pumptec</b> and <b>Pumptec</b> will not reset (turn power off for 5 seconds then back on to reset).</li> </ul>
<p><b>If your pump/motor will not run at all.</b></p>	<ul style="list-style-type: none"> <li>A. Check voltage.</li> <li>B. Check wiring.</li> <li>C. Remove the <b>QD Pumptec</b> from the control box. Reconnect wires in box to original state. If motor does not run the problem is not <b>QD Pumptec</b>. Bypass <b>Pumptec</b> by connecting L2 and motor lead with jumper. Motor should run. If not, the problem is not <b>Pumptec</b>.</li> <li>D. On <b>Pumptec</b> only check that <b>Pumptec</b> is installed between the control switch and the motor.</li> </ul>
<p><b>If your QD Pumptec or Pumptec will not trip when the pump breaks suction.</b></p>	<ul style="list-style-type: none"> <li>A. Be sure you have a Franklin motor.</li> <li>B. Check wiring connections. On <b>Pumptec</b> is lead power (230 V or 115 V) connected to correct terminal? Is motor lead connected to correct terminal?</li> <li>C. Check for ground fault in the motor and excessive friction in the pump.</li> <li>D. The well may be “gulping” enough water to keep <b>QD Pumptec</b> or <b>Pumptec</b> from tripping. It may be necessary to adjust the <b>QD Pumptec</b> or the <b>Pumptec</b> for these extreme applications. Call the Franklin Electric Service Hotline at 800-348-2420 for information.</li> <li>E. On <b>Pumptec</b> applications does the control box have a run capacitor? If so, <b>Pumptec</b> will not trip. (Except for Franklin 1.5 hp motors).</li> </ul>
<p><b>If your QD Pumptec or Pumptec chatters when running.</b></p>	<ul style="list-style-type: none"> <li>A. Check for low voltage.</li> <li>B. Check for waterlogged tank. Rapid cycling for any reason can cause the <b>QD Pumptec</b> or the <b>Pumptec</b> relay to chatter.</li> <li>C. On <b>Pumptec</b> make sure the L2 and motor wires are installed correctly. If they are reversed, the unit can chatter.</li> </ul>

# Electronic Products

## ELECTRONIC MAINTENANCE

### SubDrive2W, 75, 100, 150, 300, MonoDrive, and MonoDrive XT

Should an application or system problem occur, built-in diagnostics will protect the system. The "FAULT" light or digital display on the front of the SubDrive/MonoDrive Controller will flash a given number of times or display a number indicating the nature of the fault. In some cases, the system will shut itself off until corrective action is taken. Fault codes and their corrective actions are listed below. See SubDrive/MonoDrive Installation Manual for installation data.

#### Diagnostic Fault Codes

NUMBER OF FLASHES OR DIGITAL DISPLAY	FAULT	POSSIBLE CAUSE	CORRECTIVE ACTION
1	MOTOR UNDERLOAD	<ul style="list-style-type: none"> <li>- Overpumped well</li> <li>- Broken shaft or coupling</li> <li>- Blocked screen, worn pump</li> <li>- Air/gas locked pump</li> <li>- SubDrive not set properly for pump end</li> </ul>	<ul style="list-style-type: none"> <li>- Frequency near maximum with less than 65% of expected load, 42% if DIP #3 is "on"</li> <li>- System is drawing down to pump inlet (out of water)</li> <li>- High static, light loading pump - reset DIP switch #3 to "on" for less sensitivity if not out of water</li> <li>- Check pump rotation (SubDrive only) reconnect if necessary for proper rotation</li> <li>- Air/gas locked pump - if possible, set deeper in well to reduce</li> <li>- Verify DIP switches are set properly</li> </ul>
2	UNDERVOLTAGE	<ul style="list-style-type: none"> <li>- Low line voltage</li> <li>- Misconnected input leads</li> <li>- Dragging or failed cooling fan</li> </ul>	<ul style="list-style-type: none"> <li>- Line voltage low, less than approximately 150 VAC (normal operating range = 190 to 260 VAC)</li> <li>- Check incoming power connection and correct or tighten if necessary correct incoming voltage - check circuit breaker or fuses, contact power company</li> <li>- Disconnect fan. Re-apply system power. If 2-flash goes away, replace fan. If 2-flash continues, replace controller. Check fan with 9 Volt battery.</li> </ul>
3	LOCKED PUMP	<ul style="list-style-type: none"> <li>- Motor and/or pump misalignment</li> <li>- Dragging motor and/or pump</li> <li>- Abrasives in pump</li> <li>- Low Insulation to Ground</li> </ul>	<ul style="list-style-type: none"> <li>- Line voltage low, less than approximately 150 VAC (normal operating range = 190 to 260 VAC)</li> <li>- Amperage above max amps at 10 Hz</li> <li>- Remove and repair or replace as required</li> <li>- Check line to ground with a megohmmeter</li> <li>- Are output leads to motor longer than 1000 feet?</li> </ul>
4 (MonoDrive & MonoDriveXT only)	INCORRECTLY WIRED	<ul style="list-style-type: none"> <li>- MonoDrive only</li> <li>- Wrong resistance values on main and start</li> </ul>	<ul style="list-style-type: none"> <li>- Wrong resistance on DC test at start</li> <li>- Check wiring, check motor size, and DIP switch setting, adjust or repair as needed</li> </ul>
5	OPEN CIRCUIT	<ul style="list-style-type: none"> <li>- Loose connection</li> <li>- Failed motor or drop cable</li> <li>- Wrong motor</li> <li>- Damaged controller</li> </ul>	<ul style="list-style-type: none"> <li>- Open reading on DC test at start</li> <li>- Check drop cable and motor resistance, tighten output connections, repair or replace as necessary, use "dry" motor to check drive functions, if drive will not run and exhibits open circuit fault, replace drive</li> <li>- Check ratings</li> <li>- Replace controller</li> </ul>
6	OVER CURRENT	<ul style="list-style-type: none"> <li>- When fault is indicated immediately after power-up, over current is due to short circuit. Check for loose connections, defective cable, defective splice or grounded motor.</li> </ul>	<ul style="list-style-type: none"> <li>- Amperage exceeded 50 amps on DC test at start or max amps during running</li> <li>- Incorrect output wiring, phase to phase short, phase to ground short in wiring or motor</li> <li>- If fault is present after resetting and removing motor leads, replace drive</li> </ul>
		<ul style="list-style-type: none"> <li>- When fault is indicated while motor is running, over current due to loose debris trapped in pump</li> </ul>	<ul style="list-style-type: none"> <li>- Check pump</li> </ul>
7	OVERHEATED DRIVE	<ul style="list-style-type: none"> <li>- High ambient temperature</li> <li>- Direct sunlight</li> <li>- Obstruction of airflow</li> </ul>	<ul style="list-style-type: none"> <li>- Drive heat sink has exceeded max rated temperature, needs to drop below 85 °C to restart</li> <li>- Fan blocked or inoperable, ambient above 125 °F, direct sunlight, air flow blocked</li> <li>- Replace fan or relocate drive as necessary</li> </ul>
8 (SubDrive300 only)	OVER PRESSURE	<ul style="list-style-type: none"> <li>- Improper pre-charge</li> <li>- Valve closing too fast</li> <li>- Pressure setting too close to relief valve rating</li> </ul>	<ul style="list-style-type: none"> <li>- Reset the pre-charge pressure to 70% of sensor setting. Reduce pressure setting well below relief valve rating. Use next size larger pressure tank.</li> <li>- Verify valve operation is within manufacturer's specifications.</li> <li>- Reduce system pressure setting to a value less than pressure relief rating.</li> </ul>
<b>RAPID</b>	INTERNAL FAULT	<ul style="list-style-type: none"> <li>- A fault was found internal to drive</li> </ul>	<ul style="list-style-type: none"> <li>- Unit may require replacement. Contact your supplier.</li> </ul>
9 (SubDrive2W only)	OVER RANGE (Values outside normal operating range)	<ul style="list-style-type: none"> <li>- Wrong hp/voltage</li> <li>- Internal fault</li> </ul>	<ul style="list-style-type: none"> <li>- Verify motor hp and voltage</li> <li>- Unit may require replacement. Contact your supplier.</li> </ul>

# Electronic Products

## ELECTRONIC MAINTENANCE

### SubDrive15, 20, 30, MonoDrive, and MonoDriveXT (NEMA 3R)

#### Diagnostic Fault Codes

NUMBER OF FLASHES	FAULT	POSSIBLE CAUSE	CORRECTIVE ACTION
<b>F1</b>	MOTOR UNDERLOAD	<ul style="list-style-type: none"> <li>- Overpumped well</li> <li>- Broken shaft or coupling</li> <li>- Blocked screen, worn pump</li> <li>- Air/gas locked pump</li> <li>- SubDrive not set properly for pump end</li> <li>- Underload Sensitivity setting incorrect</li> </ul>	<ul style="list-style-type: none"> <li>- Frequency near maximum with load less than configured underload sensitivity (Potentiometer or Wi-Fi)</li> <li>- System is drawing down to pump inlet (out of water)</li> <li>- High static, light loading pump - reset Potentiometer for less sensitivity if not out of water</li> <li>- Check pump rotation (SubDrive only) reconnect if necessary for proper rotation</li> <li>- Air/gas locked pump - if possible, set deeper in well to reduce</li> <li>- Verify DIP switches are set properly</li> <li>- Check Underload Sensitivity Setting (Potentiometer or Wi-Fi setting, whichever is applicable)</li> </ul>
<b>F2</b>	UNDERVOLTAGE	<ul style="list-style-type: none"> <li>- Low line voltage</li> <li>- Mismatched input leads</li> <li>- Loose connection at breaker or panel</li> </ul>	<ul style="list-style-type: none"> <li>- Line voltage low, less than approximately 150 VAC (normal operating range = 190 to 260 VAC)</li> <li>- Check incoming power connections and correct or tighten if necessary</li> <li>- Correct incoming voltage - check circuit breaker or fuses, contact power company</li> </ul>
<b>F3</b>	OVERCURRENT / LOCKED PUMP	<ul style="list-style-type: none"> <li>- Motor and/or pump misalignment</li> <li>- Dragging motor and/or pump</li> <li>- Motor and/or pump locked</li> <li>- Abrasives in pump</li> <li>- Excess motor cable length</li> </ul>	<ul style="list-style-type: none"> <li>- Amperage above SFL at 30 Hz</li> <li>- Remove and repair or replace as required</li> <li>- Reduce motor cable length. Adhere to Maximum Motor Cable Length table.</li> </ul>
<b>F4</b> (MonoDrive & MonoDriveXT only)	INCORRECTLY WIRED	<ul style="list-style-type: none"> <li>- MonoDrive only</li> <li>- Wrong resistance values on main and start</li> </ul>	<ul style="list-style-type: none"> <li>- Wrong resistance on DC test at start</li> <li>- Check wiring, check motor size and DIP switch setting, adjust or repair as needed</li> </ul>
<b>F5</b>	OPEN PHASE	<ul style="list-style-type: none"> <li>- Loose connection</li> <li>- Defective motor or drop cable</li> <li>- Wrong motor</li> </ul>	<ul style="list-style-type: none"> <li>- Open reading on DC test at start</li> <li>- Check drop cable and motor resistance, tighten output connections, repair or replace as necessary, use "dry" motor to check drive functions. If drive will not run and exhibits underload fault replace drive</li> </ul>
<b>F6</b>	SHORT CIRCUIT	<ul style="list-style-type: none"> <li>- When fault is indicated immediately after power-up, short circuit due to loose connection, defective cable, splice or motor</li> </ul>	<ul style="list-style-type: none"> <li>- Amperage exceeded 25 amps on DC test at start or SF amps during running</li> <li>- Incorrect output wiring, phase to phase short, phase to ground short in wiring or motor</li> <li>- If fault is present after resetting and removing motor leads, replace drive</li> </ul>
<b>F7</b>	OVERHEATED DRIVE	<ul style="list-style-type: none"> <li>- High ambient temperature</li> <li>- Direct sunlight</li> <li>- Obstruction of airflow</li> </ul>	<ul style="list-style-type: none"> <li>- Drive heat sink has exceeded max rated temperature, needs to drop below 194 °F (90 °C) to restart</li> <li>- Fan blocked or inoperable, ambient above 122 °F (50 °C), direct sunlight, air flow blocked</li> <li>- Replace fan or relocate drive as necessary</li> <li>- Remove debris from fan intake/exhaust</li> <li>- Remove and clean optional air screen kit (if installed)</li> </ul>
<b>F9</b>	INTERNAL PCB FAULT	<ul style="list-style-type: none"> <li>- A fault was found internal to drive</li> </ul>	<ul style="list-style-type: none"> <li>- Contact your Franklin Electric Service Personnel</li> <li>- Unit may require replacement. Contact your supplier.</li> </ul>
<b>F12</b>	OVERVOLTAGE	<ul style="list-style-type: none"> <li>- High line voltage</li> <li>- Internal voltage too high</li> </ul>	<ul style="list-style-type: none"> <li>- Line voltage high</li> <li>- Check incoming power connections and correct or tighten if necessary</li> <li>- If line voltage is stable and measured below 260 VAC and problem persists, contact your Franklin Electric Service Personnel</li> </ul>

Power down, disconnect leads to the motor and power up the SubDrive:

- If the SubDrive does not give an "open phase" fault (F5), then there is a problem with the SubDrive.
- Connect the SubDrive to a dry motor. If the motor goes through DC test and gives "underload" fault (F1), the SubDrive is working properly.

# Electronic Products

## ELECTRONIC MAINTENANCE

### SubDrive15, 20, 30, MonoDrive, and MonoDriveXT (NEMA 3R) (Continued)

#### Diagnostic Fault Codes

NUMBER OF FLASHES	FAULT	POSSIBLE CAUSE	CORRECTIVE ACTION
<b>F14</b>	BROKEN PIPE	<ul style="list-style-type: none"> <li>- Broken pipe or large leak is detected in the system</li> <li>- Drive runs at full power for 10 minutes without reaching pressure setpoint</li> <li>- Large water draw, such as a sprinkler system, does not allow system to reach pressure setpoint</li> </ul>	<ul style="list-style-type: none"> <li>- Check system for large leak or broken pipe</li> <li>- If the system contains a sprinkler system or is being used to fill a pool or cistern, disable the Broken Pipe Detection</li> </ul>
<b>F15</b> (SD15/20/30 only)	PHASE IMBALANCE	<ul style="list-style-type: none"> <li>- Motor phase currents differ by 20% or more.</li> <li>- Motor is worn internally</li> <li>- Motor cable resistance is not equal</li> <li>- Incorrect motor type setting (single- or three-phase)</li> </ul>	<ul style="list-style-type: none"> <li>- Check resistance of motor cable and motor windings</li> <li>- Verify motor type matched drive settings (single- or three-phase)</li> </ul>
<b>F16</b>	GROUND FAULT	<ul style="list-style-type: none"> <li>- Motor output cable is damaged or exposed to water</li> <li>- Phase to ground short</li> </ul>	<ul style="list-style-type: none"> <li>- Check motor cable insulation resistance with megger (while not connected to drive). Replace motor cable if needed.</li> </ul>
<b>F17</b>	INVERTER TEMPERATURE SENSOR FAULT	<ul style="list-style-type: none"> <li>- Internal temperature sensor is malfunctioning</li> </ul>	<ul style="list-style-type: none"> <li>- Contact your Franklin Electric Service Personnel</li> <li>- If problem persists, unit may require replacement. Contact your supplier.</li> </ul>
<b>F18</b> (SD20/30/MDXT only)	PFC TEMPERATURE SENSOR FAULT	<ul style="list-style-type: none"> <li>- Internal temperature sensor is malfunctioning</li> </ul>	<ul style="list-style-type: none"> <li>- Contact your Franklin Electric Service Personnel</li> <li>- If problem persists, unit may require replacement. Contact your supplier.</li> </ul>
<b>F19</b>	COMMUNICATION FAULT	<ul style="list-style-type: none"> <li>- Cable connection between Display/Wi-Fi Board and Main Control Board is loose or disconnected</li> <li>- Internal circuit failure</li> </ul>	<ul style="list-style-type: none"> <li>- Check cable connection between Display/Wi-Fi Board and Main Control Board.</li> <li>- If problem persists, unit may require replacement. Contact your supplier.</li> </ul>
<b>F22</b>	DISPLAY/WI-FI BOARD EXPECTED FAULT	<ul style="list-style-type: none"> <li>- Connection between Display/Wi-Fi Board and Main Control Board was not detected at drive start-up</li> </ul>	<ul style="list-style-type: none"> <li>- Check cable connection between Display/Wi-Fi Board and Main Control Board.</li> <li>- If problem persists, unit may require replacement. Contact your supplier.</li> </ul>
<b>F23</b>	MAIN BOARD STARTUP FAULT	<ul style="list-style-type: none"> <li>- A fault was found internal to drive</li> </ul>	<ul style="list-style-type: none"> <li>- Contact your Franklin Electric Service Personnel</li> <li>- Unit may require replacement. Contact your supplier.</li> </ul>
<b>F24</b>	INVALID DIP SWITCH SETTING	<ul style="list-style-type: none"> <li>- No DIP Switch set or more than one (1) DIP switch set for motor size</li> <li>- No DIP Switch set or more than one (1) DIP switch set for pump size</li> <li>- Invalid combination of DIP switches for drive type (SD or MD mode), motor hp, and pump hp.</li> </ul>	<ul style="list-style-type: none"> <li>- Check DIP switch settings</li> </ul>

Power down, disconnect leads to the motor and power up the SubDrive:

- If the SubDrive does not give an "open phase" fault (F5), then there is a problem with the SubDrive.
- Connect the SubDrive to a dry motor. If the motor goes through DC test and gives "underload" fault (F1), the SubDrive is working properly.

# Electronic Products

## ELECTRONIC MAINTENANCE

### SubDrive2W, 75, 100, 150, 300, MonoDrive, and MonoDrive XT

#### Troubleshooting

CONDITION	INDICATOR LIGHT	POSSIBLE CAUSE	CORRECTIVE ACTION
NO WATER	NONE	- No supply voltage present	- If correct voltage is present, replace drive
	SOLID GREEN	- Pressure sensor circuit	- Verify water pressure is below system set point - Jumper wires together at pressure sensor, if pump starts, replace sensor - If pump doesn't start, check sensor connection at printed circuit board (PCB), if loose, repair - If pump doesn't start, jumper sensor connection at PCB, if pump starts, replace wire - If pump doesn't start with sensor PCB connection jumpered, replace drive
	SOLID RED OR SOLID RED AND GREEN	- Power surge, bad component	- Power system down to clear fault, verify voltage, if repetitive, replace drive
	FLASHING RED	- Fault detected	- Proceed to fault code description and remedy
	FLASHING GREEN	- Drive and motor are operating  - Loose switch or cable connection - Gulping water at pump inlet	- Frequency max, amps low, check for closed valve, or stuck check valve - Frequency max, amps high, check for hole in pipe - Frequency max, amps erratic, check pump operation, dragging impellers - This is not a drive problem - Check all connections - Disconnect power and allow well to recover for short time, then retry
PRESSURE FLUCTUATIONS (POOR REGULATION)	FLASHING GREEN	- Pressure sensor placement and setting - Pressure gauge placement - Pressure tank size and pre-charge - Leak in system - Air entrainment into pump intake (lack of submergence)	- Correct pressure and placement as necessary - Tank may be too small for system flow - This is not a drive problem - Disconnect power and check pressure gauge for pressure drop - Set deeper in the well or tank; install a flow sleeve with airtight seal around drop pipe and cable - If fluctuation is only on branches before sensor, flip DIP switch #4 to "on" (O7C and newer)
RUN ON WON'T SHUT DOWN	FLASHING GREEN	- Pressure sensor placement and setting - Tank pre-charge pressure - Impeller damage - Leaky system - Sized improperly (pump can't build enough head)	- Check frequency at low flows, pressure setting may be too close to pump max head - Verify precharge at 70% if tank size is larger than minimum, increase precharge (up to 85%) - Verify that the system will build and hold pressure
RUNS BUT TRIPS	FLASHING RED	- Check fault code and see corrective action	- Proceed to fault code description and remedy on reverse side
LOW PRESSURE	FLASHING GREEN	- Pressure sensor setting, pump rotation, pump sizing	- Adjust pressure sensor, check pump rotation - Check frequency at max flow, check max pressure
HIGH PRESSURE	FLASHING GREEN	- Pressure sensor setting - Shorted sensor wire	- Adjust pressure sensor - Remove sensor wire at PCB, if drive continues to run, replace drive - Verify condition of sensor wire and repair or replace if necessary
AUDIBLE NOISE	FLASHING GREEN	- Fan, hydraulic, plumbing	- For excessive fan noise, replace fan - If fan noise is normal, drive will need to be relocated to a more remote area - If hydraulic, try raising or lowering depth of pump - Pressure tank location should be at entrance of water line into house
NO LIGHTS	NONE	- Ribbon cable detached from LED printed circuit board	- Reattach cable - if cable is attached, replace drive
RFI-EMI INTERFERENCE	FLASHING GREEN	- See interference troubleshooting procedure	

# Electronic Products

## ELECTRONIC MAINTENANCE

### SubDrive15, 20, 30, MonoDrive, and MonoDriveXT (NEMA 3R)

#### Troubleshooting

CONDITION	INDICATOR LIGHT	POSSIBLE CAUSE	CORRECTIVE ACTION
NO WATER	NONE	<ul style="list-style-type: none"> <li>- No supply voltage present</li> <li>- Display board cable disconnected or loose</li> </ul>	<ul style="list-style-type: none"> <li>- Verify cable connection between main control board and display board</li> <li>- If correct voltage is present, replace drive</li> </ul>
	GREEN "---" ON DISPLAY	<ul style="list-style-type: none"> <li>- Pressure sensor circuit</li> </ul>	<ul style="list-style-type: none"> <li>- Verify water pressure is below system set point</li> <li>- If Pressure Input Board break-away tab is removed, ensure auxiliary device is connected and closed circuit</li> <li>- If Pressure Input Board break-away tab is removed and no auxiliary device is being used, manually short-circuit "AUX IN" connections</li> <li>- Jumper wires together at pressure sensor; if pump starts, replace sensor</li> <li>- If pump doesn't start, check sensor connection at Pressure Input Board; if loose, repair</li> <li>- If pump doesn't start, jumper sensor connection at Pressure Input Board. If pump starts, replace wire</li> <li>- If pump doesn't start with sensor Pressure Input Board connection jumpered, replace Pressure Input Board</li> <li>- If pump doesn't start with new Pressure Input Board, replace drive</li> </ul>
	RED FAULT CODE ON DISPLAY	<ul style="list-style-type: none"> <li>- Fault detected</li> </ul>	<ul style="list-style-type: none"> <li>- Proceed to fault code description and remedy</li> </ul>
	GREEN MOTOR FREQUENCY ON DISPLAY	<ul style="list-style-type: none"> <li>- Drive and motor are operating</li> <li>- Loose switch or cable connection</li> <li>- Incorrect motor or pump settings</li> <li>- Motor may be running backwards</li> <li>- Gulping water at pump inlet</li> </ul>	<ul style="list-style-type: none"> <li>- Verify Maximum Frequency setting. If this setting was reduced below maximum value, increase</li> <li>- Verify motor/pump ratings and match to motor/pump settings on drive (DIP switch or Wi-Fi)</li> <li>- Verify motor connections</li> <li>- Frequency max, amps low, check for closed valve, or stuck check valve</li> <li>- Frequency max, amps high, check for hole in pipe</li> <li>- Frequency max, amps erratic, check pump operation, dragging impellers</li> <li>- This is not a drive problem</li> <li>- Check all connections</li> <li>- Disconnect power and allow well to recover for short time, then retry</li> </ul>
PRESSURE FLUCTUATIONS (POOR REGULATION)	GREEN MOTOR FREQUENCY ON DISPLAY	<ul style="list-style-type: none"> <li>- Pressure sensor placement and setting</li> <li>- Pressure gauge placement</li> <li>- Pressure tank size and pre-charge</li> <li>- Leak in system</li> <li>- Air entrainment into pump intake (lack of submergence)</li> </ul>	<ul style="list-style-type: none"> <li>- Correct pressure and placement as necessary</li> <li>- Tank may be too small for system flow</li> <li>- This is not a drive problem</li> <li>- Disconnect power and check pressure gauge for pressure drop</li> <li>- Change tank size configuration</li> <li>- Set deeper in the well or tank; install a flow sleeve with airtight seal around drop pipe and cable</li> <li>- If fluctuation is only on branches before sensor, enable Steady Flow</li> </ul>
RUN ON WON'T SHUT DOWN	GREEN MOTOR FREQUENCY ON DISPLAY	<ul style="list-style-type: none"> <li>- Pressure sensor placement and setting</li> <li>- Tank pre-charge pressure</li> <li>- Impeller damage</li> <li>- Leaky system</li> <li>- Sized improperly (pump can't build enough head)</li> </ul>	<ul style="list-style-type: none"> <li>- Check frequency at low flows, pressure setting may be too close to pump max head</li> <li>- Verify precharge at 70% if tank size is larger than minimum, increase precharge (up to 85%)</li> <li>- Verify that the system will build and hold pressure</li> <li>- Enable bump and/or aggressive bump</li> <li>- Increase minimum frequency</li> </ul>
RUNS BUT TRIPS	FLASHING RED	<ul style="list-style-type: none"> <li>- Check fault code and see corrective action</li> </ul>	<ul style="list-style-type: none"> <li>- Proceed to fault code description and remedy on reverse side</li> </ul>

Continued on next page

# Electronic Products

## ELECTRONIC MAINTENANCE

### SubDrive15, 20, 30, MonoDrive, and MonoDriveXT (NEMA 3R) (Continued)

#### Troubleshooting

CONDITION	INDICATOR LIGHT	POSSIBLE CAUSE	CORRECTIVE ACTION
LOW PRESSURE	GREEN MOTOR FREQUENCY ON DISPLAY	<ul style="list-style-type: none"> <li>- Pressure sensor setting, pump rotation, pump sizing</li> <li>- High temperature</li> </ul>	<ul style="list-style-type: none"> <li>- Adjust pressure sensor, check pump rotation</li> <li>- Check frequency at max flow, check max pressure</li> <li>- High ambient and/or drive temperature will cause drive to foldback power and run with reduced performance</li> </ul>
HIGH PRESSURE	GREEN MOTOR FREQUENCY ON DISPLAY	<ul style="list-style-type: none"> <li>- Pressure sensor setting</li> <li>- Shorted sensor wire</li> </ul>	<ul style="list-style-type: none"> <li>- Adjust pressure sensor</li> <li>- Remove sensor wire at Pressure Input Board, if drive stops running, wire may be shorted</li> <li>- Remove sensor wire at Pressure Input Board, if drive continues to run, replace Pressure Input Board</li> <li>- Remove sensor wire at new Pressure Input Board, if drive continues to run, replace drive</li> <li>- Verify condition of sensor wire and repair or replace if necessary</li> </ul>
AUDIBLE NOISE	GREEN MOTOR FREQUENCY ON DISPLAY	<ul style="list-style-type: none"> <li>- Fan, hydraulic, plumbing</li> </ul>	<ul style="list-style-type: none"> <li>- For excessive fan noise, replace fan</li> <li>- If fan noise is normal, drive will need to be relocated to a more remote area</li> <li>- If hydraulic, try raising or lowering depth of pump</li> <li>- Pressure tank location should be at entrance of water line into house</li> </ul>
NO DISPLAY	NONE	<ul style="list-style-type: none"> <li>- Display board cable disconnected or loose</li> </ul>	<ul style="list-style-type: none"> <li>- Verify cable connection between main control board and display board</li> </ul>
CANNOT CONNECT TO DRIVE WI-FI	FE CONNECT LIGHT ON SOLID	<ul style="list-style-type: none"> <li>- Attempting to connect to incorrect drive</li> <li>- Out of Wi-Fi range of drive</li> </ul>	<ul style="list-style-type: none"> <li>- Ensure the Wi-Fi SSID (hotspot name) you are connecting to matches the drive you wish to connect to</li> <li>- Wi-Fi range is 100 feet line-of-site, must be closer to drive if walls or floors are between you and the drive</li> <li>- Wi-Fi module not responding, cycle power to drive</li> <li>- Cycle Wi-Fi radio on mobile device, refresh Wi-Fi connection list</li> </ul>
	FE CONNECT LIGHT OFF	<ul style="list-style-type: none"> <li>- Wi-Fi timeout expired</li> </ul>	<ul style="list-style-type: none"> <li>- If more than fifteen (15) minutes since last power cycle, cycle power to drive</li> <li>- If more than one (1) hour since last disconnection from Wi-Fi, cycle power to drive</li> </ul>
RFI-EMI INTERFERENCE	GREEN MOTOR FREQUENCY ON DISPLAY	<ul style="list-style-type: none"> <li>- Poor grounding</li> <li>- Wire routing</li> </ul>	<ul style="list-style-type: none"> <li>- Adhere to grounding and wire routing recommendations</li> <li>- An additional external filter may be needed. See Accessories section for ordering information</li> </ul>

# Electronic Products

## ELECTRONIC MAINTENANCE

### SubMonitor

#### SubMonitor Troubleshooting

FAULT MESSAGE	PROBLEM/CONDITION	POSSIBLE CAUSE
<b>SF Amps Set Too High</b>	SF Amps setting above 359 Amps	Motor SF Amps not entered
<b>Phase Reversal</b>	Reversed incoming voltage phase sequence	Incoming power problem
<b>Underload</b>	Normal line current	Wrong SF Max Amps setting
	Low line current	Over pumping well Clogged pump intake Closed valve Loose pump impeller Broken shaft or coupling Phase loss
<b>Overload</b>	Normal line current	Wrong SF Max Amps setting
	High line current	High or low line voltage Ground fault Pump or motor dragging Motor stalled or bound pump
<b>Overheat</b>	Motor temperature sensor has detected excess motor temperature	High or low line voltage Motor is overloaded Excessive current unbalance Poor motor cooling High water temperature Excessive electrical noise (VFD in close proximity)
<b>Unbalance</b>	Current difference between any two legs exceeds programmed setting	Phase loss. Unbalanced power supply. Open Delta transformer.
<b>Overvoltage</b>	Line voltage exceeds programmed setting	Unstable power supply.
<b>Undervoltage</b>	Line voltage below programmed setting	Poor connection in motor power circuit. Unstable or weak power supply.
<b>False Starts</b>	Power has been interrupted too many times in a 10 second period	Chattering contacts. Loose connections in motor power circuit. Arcing contacts.



# Notes

## AIM MANUAL

A	Amp or amperage	MCM	Thousand Circular Mils
AWG	American Wire Gauge	mm	Millimeter
BJT	Bipolar Junction Transistor	MOV	Metal Oxide Varistor
°C	Degree Celsius	NEC	National Electrical Code
CB	Control Box	NEMA	National Electrical Manufacturer Association
CRC	Capacitor Run Control	Nm	Newton Meter
DI	Deionized	NPSH	Net Positive Suction Head
DOL	Direct on Line	OD	Outside Diameter
Dv/dt	Rise Time of the Voltage	OL	Overload
EFF	Efficiency	PF	Power Factor
°F	Degree Fahrenheit	psi	Pounds per Square Inch
FDA	Food & Drug Administration	PWM	Pulse Width Modulation
FL	Full Load	QD	Quick Disconnect
ft	Foot	R	Resistance
ft-lb	Foot Pound	RMA	Return Material Authorization
ft/s	Feet per Second	RMS	Root Mean Squared
GFCI	Ground Fault Circuit Interrupter	rpm	Revolutions per Minute
gpm	Gallons per Minute	SF	Service Factor
HERO	High Efficiency Reverse Osmosis	SFhp	Service Factor Horsepower
hp	Horsepower	S/N	Serial Number
Hz	Hertz	TDH	Total Dynamic Head
ID	Inside Diameter	UNF	Fine Thread
IGBT	Insulated Gate Bipolar Transistor	V	Voltage
in	Inch	VAC	Voltage Alternating Current
kVA	Kilovolt Amp	VDC	Voltage Direct Current
kVAR	Kilovolt Amp Rating	VFD	Variable Frequency Drive
kW	Kilowatt (1000 watts)	W	Watts
L1, L2, L3	Line One, Line Two, Line Three	XFMR	Transformer
lb-ft	Pound Feet	Y-D	Wye-Delta
L/min	Liter per Minute	Ω	ohms
mA	Milliamp		
max	Maximum		

# Notes

AIM MANUAL



# 2022 EDITION

## FRANKLIN ELECTRIC TECHNICAL SUPPORT 800-348-2420 | 260-827-5102 FAX

**Option 1** - Franklin Water | **Option 2** - Franklin Control System | **Option 3** - Little Giant Commercial | **Option 4** - Water Treatment

Call Franklin's toll free TECHNICAL SUPPORT LINE for answers to your pump and motor installation questions. When you call, a Franklin expert will offer assistance in troubleshooting and provide immediate answers to your system application questions. Technical support is also available online.

[franklinwater.com](http://franklinwater.com) | [franklin-controls.com](http://franklin-controls.com) | [solar.franklin-electric.com](http://solar.franklin-electric.com) | [constantpressure.com](http://constantpressure.com)

